

# ***LX7007 pro IGC***

---

## ***V2.01***

---

**Variometer and GPS-Navigation System**  
With Flarm option, SD card interface, Distance Measuring Equipment and  
Competition Mode



**LX navigation** d.o.o.

Tkalska 10 SLO 3000 Celje

+ 386 3 490 46 70

support@lxnavigation.si

+ 386 3 490 46 71

<http://www.lxnavigation.si>

# Contents

<b>1</b>	<b>GENERAL.....</b>	<b>6</b>
1.1	TECHNICAL DATA .....	7
1.2	OPTIONS.....	8
1.2.1	Double seater configuration .....	8
1.2.2	Remote control.....	8
1.2.3	Flarm .....	8
<b>2</b>	<b>SYSTEM DESCRIPTION.....</b>	<b>9</b>
2.1	ROTARY SWITCHES AND KEYS (BUTTONS) .....	9
2.1.1	ON/START button - Switching the Instrument ON and OFF .....	9
2.1.2	MODE selector (rotary switch) ⇔.....	10
2.1.3	AUDIO Volume selector .....	10
2.1.4	UP/DOWN selector (rotary switch) ⚡.....	10
2.1.5	ZOOM Rotary switch.....	11
2.1.6	ENTER button.....	11
2.1.7	ESC/OFF button.....	11
2.1.8	EVENT button.....	11
2.1.9	MC and BAL buttons.....	11
2.2	OPERATING MODES.....	12
2.3	SETUP.....	13
2.3.1	SETUP (First level).....	13
2.3.1.1	QNH RES (QNH and Safety Altitude input).....	13
2.3.1.2	LOGGER (Input of flight recorder parameters).....	14
2.3.1.3	INIT (Input of variometer parameters).....	17
2.3.1.4	DISPLAY.....	18
2.3.1.5	TRANSFER.....	18
2.3.2	COMPETITION Mode.....	19
2.3.3	SYSTEM SETUP (Second level).....	19
2.3.3.1	AS SELECT (Selection of airspace section).....	19
2.3.3.2	VOICE MODULE.....	20
2.3.3.3	TP (Turn point).....	21
2.3.3.4	OBS. ZONE (Observation Zone).....	22
2.3.3.4.1	START ZONE.....	23
2.3.3.4.2	POINT ZONE.....	24
2.3.3.4.3	FINISH ZONE .....	25
2.3.3.4.4	Using of LXe for zone preparation .....	26
2.3.3.5	WARNINGS ( Airspace Penetration and Height Warnings).....	26
2.3.3.5.1	Airspace Warnings .....	26
2.3.3.5.2	Detailed AS screen.....	27
2.3.3.5.3	Altitude Warning.....	28
2.3.3.6	GPS (UTC offset and earth datum).....	28
2.3.3.7	UNITS.....	29
2.3.3.8	GRAPHIC.....	29
2.3.3.8.1	SYMBOL.....	29
2.3.3.8.2	AIRSPACE (Graphics).....	30
2.3.3.8.3	APT (Graphics).....	31
2.3.3.8.4	TP (Graphics).....	31
2.3.3.9	PILOTS (Pilot list).....	32
2.3.3.10	NMEA/PDA (NMEA output for PDA).....	33
2.3.3.11	USER PORT .....	34
2.3.3.12	DEL TP/TSK.....	34
2.3.3.13	POLAR.....	34
2.3.3.14	LOAD.....	34
2.3.3.15	TE COMP. (Total energy compensation).....	35
2.3.3.16	INPUT (external SC switch).....	36
2.3.3.17	LCD IND. (LCD – Vario Indicator).....	36
2.3.3.18	COMPASS .....	38
2.3.3.19	ENGINE (Engine Noise Level) .....	38
2.3.3.20	PAGE 1 (Main Navigation Page).....	39
2.3.3.21	PAGE 3 (Additional Navigation Page).....	39
2.3.3.22	AUDIO (Adjustment of audio ).....	40
2.3.3.23	ALARMS .....	40
2.3.3.24	FLARM .....	40
2.3.3.24.1	SETTINGS .....	41
2.3.3.24.2	TRAFFIC INFO (Flarm traffic information display).....	41

2.3.3.24.3	TURN OFF (TURN ON).....	41
2.3.3.24.4	TIME LOCK (Flarm).....	41
2.3.3.25	SD CARD (SD card formatting).....	42
2.3.3.26	INTERFACES (Options).....	42
2.3.3.27	PASSWORD.....	42
2.3.3.28	INFO.....	42
2.4	NAVIGATION FUNCTIONS.....	43
2.4.1	GPS Page.....	43
2.4.2	NEAR AIRPORT.....	43
2.4.3	APT Airports, TP Turn Points and TSK Tasks.....	44
2.4.3.1	Navigation in APT, TP or TSK.....	44
2.4.3.2	Airport Selection, Team and Wind Calculation.....	46
2.4.3.2.1	SELECT - Airport Selection.....	47
2.4.3.2.2	TEAM function.....	48
2.4.3.2.3	WIND calculation method selection.....	48
2.4.4	TP - Turn Points.....	49
2.4.4.1	TP SELECT.....	50
2.4.4.2	TP EDIT.....	51
2.4.4.3	TP NEW.....	51
2.4.4.4	TP delete.....	51
2.4.4.5	TEAM.....	51
2.4.4.6	WIND.....	51
2.4.4.7	Storing of Actual Position.....	52
2.4.5	TSK - Task.....	52
2.4.5.1	TSK - SELECT.....	53
2.4.5.2	TSK - EDIT.....	54
2.4.5.3	TSK - NEW.....	56
2.4.5.4	TSK - DECLARE.....	56
2.4.5.4.1	Declaration using of LXe, Colibri/LX20 or PDA.....	57
2.4.5.4.2	Declaration after using of SC card.....	57
2.4.6	START OPTIONS.....	57
2.4.7	STATISTICS.....	57
2.4.7.1	Statistics during flight.....	57
2.4.7.1.1	Flight statistics.....	57
2.4.7.1.2	TSK Statistics.....	58
2.4.7.2	Statistics after flight.....	58
2.4.7.2.1	LOGBOOK.....	58
2.4.7.2.2	Statistics after flight.....	58
2.5	VARIOMETER AND ALTIMETER.....	60
2.5.1	Smart Vario description.....	60
2.5.2	Altimeter.....	61
2.5.2.1	IGC barogram recalibration procedure.....	61
2.5.3	Speed command.....	61
2.5.4	Final glide calculation.....	61
<b>3</b>	<b>FLYING WITH THE LX 7007 PRO IGC.....</b>	<b>62</b>
3.1	FLIGHT PREPARATION ON GROUND.....	62
3.1.1	Single pilot option.....	62
3.1.2	Multipilot option.....	62
3.1.3	SET Elevation (take off elevation input).....	63
3.1.4	Preflight check.....	64
3.1.5	Preparing a task.....	64
3.1.5.1	AAT (assigned area task).....	64
3.1.5.1.1	How to prepare an AAT?.....	64
3.1.5.1.2	Example of an AAT.....	65
3.1.6	Task declaration procedures.....	68
3.1.7	Manual procedure.....	68
3.1.8	Using of PC.....	68
3.1.9	Using of PDA.....	69
3.2	COMPETITION MODE.....	69
3.2.1	Competition Mode Enable.....	69
3.2.2	Competition Mode Disable.....	69
3.3	PERFORMING THE FLIGHT.....	70
3.3.1	Starting a task.....	70
3.3.2	Task Restart.....	71
3.3.3	Over Turn point (flying a racing task).....	71
3.3.4	Switch over flying an AAT.....	71

3.3.4.1	Use of MOVE function.....	72
3.3.4.1.1	Automatic move function .....	72
3.3.4.1.2	Manual move .....	72
3.3.5	Statistics during flight .....	73
3.3.6	Task end.....	74
3.3.6.1	Procedure after landing .....	74
3.3.6.2	Downloading of flights .....	74
3.3.7	SIMPLE TASK (flying around TPs or APTs ) .....	75
3.3.7.1	Distance Measuring Equipment .....	75
3.3.8	Climb indicator .....	76
3.3.9	Altitude Gain indicator and Total Averager .....	76
3.3.9.1	Altitude Gain indicator .....	77
3.3.9.2	Total Averager .....	77
3.3.10	Using of PDA like secondary navigation system.....	78
3.3.10.1	LX Mobile features .....	78
3.3.10.1.1	LXMobile installation.....	78
<b>4</b>	<b>COMMUNICATION WITH PC, PDA, COLIBRI/LX20 AND SD CARD .....</b>	<b>79</b>
4.1	COMMUNICATION WITH PC .....	80
4.1.1	Downloading of Flights .....	81
4.1.2	Transfer of TP/TSK data base and Flight Info.....	81
4.1.3	Upload of Airport data base .....	81
4.1.4	Loading of airspace sections.....	81
4.1.5	IGC Shell program.....	82
4.1.6	Some help having problems with communication .....	82
4.1.6.1	General.....	82
4.1.6.2	Troubleshooting with LXE .....	82
4.1.6.2	Recommended LXE settings for safe communication .....	83
4.1.7	Having problems downloading flights (read selected flight-command).....	83
4.1.8	Additional help from LX navigation.....	84
4.2	COMMUNICATION WITH PDA .....	85
4.2.1	Using of ConnectLX/ConnectMe.....	85
1.1.1.1	Flight downloading using of PDA .....	86
4.2.1.1	Airspace and Airport data base transfer .....	86
4.3	COMMUNICATION BETWEEN LX 7007, COLIBRI OR LX 20.....	87
4.3.1	Data transfer LX 7007-LX 20 .....	87
4.3.2	Data transfer LX 7007-Colibri.....	87
4.4	DATA TRANSFER AFTER USING OF SD CARD .....	88
4.4.1	Data base data exchange .....	88
4.4.2	Downloading of flights.....	90
<b>5</b>	<b>INSTALLATION .....</b>	<b>91</b>
5.1	VARIO/SC EXTERNAL SWITCH INSTALLATION.....	93
5.2	INSTALLATION OF PDA UNITS .....	94
5.3	INSTALLATION OF OPTIONS .....	95
5.4	LX 7007 PRO IGC FULL CONFIGURATION .....	96
5.5	WIRING .....	98
5.6	TREE STRUCTURE DIAGRAM .....	100
5.7	LX 7007 MENU STRUCTURE .....	101
<b>6</b>	<b>GROUND SCHOOL .....</b>	<b>101</b>
6.1	HW CONFIGURATION.....	102
6.1.1	Input of passwords .....	102
6.2	CONDOR AND LXSIM.....	102
<b>7</b>	<b>OPTIONS .....</b>	<b>103</b>
7.1	FLARM OPTION .....	103
7.1.1	Configuration.....	103
7.1.1.1	Flarm external display .....	103
7.1.1.1.1	LX Flarm graphic display .....	104
7.1.1.1.2	LX Flarm display 57 mm.....	104
7.1.1.2	Settings .....	105
7.1.2	Installation.....	105
7.1.3	Functional check after installation .....	106
7.1.4	LX 7007 traffic information display.....	106
7.1.4.1	Glider ID customization .....	107
7.1.5	Manuals and limitations.....	107
7.1.6	Flarm firmware updates.....	108

---

Procedure Nr.1.....	109
Procedure Nr.2.....	110
7.2 LX 7007 PRO IGC - COMPASS MODULE.....	111
7.2.1 General.....	111
7.2.2 Installation of the compass module.....	112
7.2.2.1 Where to install:.....	112
7.2.3 First test after installation:.....	112
7.2.4 Adjusting the compass module:.....	112
7.2.5 Final check.....	114
7.2.6 Input of local mg. variation.....	114
7.3 LX 7007 REMOTE CONTROL.....	114
7.3.1 LX 7007 PRO IGC – Remote K- Stick mounted unit.....	114
7.3.1.1 General.....	114
7.3.1.2 LX 7007 PRO IGC Remote K configuration.....	114
7.3.1.3 Stick handle with keys.....	114
7.3.1.4 Double seater configuration.....	115
7.4 SECONDARY VARIO INDICATORS.....	115
7.5 LX 7007 D FOR SECOND SEAT.....	115
<b>8 REVISION HISTORY.....</b>	<b>115</b>

# 1 General

The instrument consists of two units, the **LX 7007 DU** main unit, and the **LX 7007 AU** LCD Vario indicator unit. The 80mm diameter (3") main unit LX 7007 DU is fitted with an integral 16 channel GPS receiver and a high resolution display with 160x240 pixels. The 57 mm diameter (2 1/4") LX 7007 AU is a modern designed vario unit with its own integral micro processor. The unit communicates with the LX 7007 DU via the RS 485 system bus. Optionally, additional LX digital Vario indicators and a wide range of interface devices can be daisy chained using the RS 485 bus.



## Vario functions include:

- Vario with audio, Netto, Relative (Super Netto) and Average
- Smart vario
- Speed command
- Final glide calculator
- TE compensation is selectable for either pneumatic TE tube, or electronic TE
- Altitude gain indicator
- Total averager of last thermal

## Navigation functions include:

- Airport and airspace database for Europe or USA (up to 5000 airports and 6 airspace sections, nearly the whole Europe)
- 600 turn points
- 100 tasks, full AAT capable
- Statistics
- Display of nearest airports and out landing fields
- Support of AAT (assigned area task)
- Distance measuring equipment in TP and APT mode
- Multi pilot function (storing of 30 pilots names with their individual settings)

## Flight recorder functions include:

- Integral pressure transducer based on 1013 mb level, for altitude recording
- Integral Engine Noise Level sensor
- Memory to store typically 100 flight hours (hardly depends on settings)
- Digital and mechanically security device to ensure high level of data security

**Interfaces:**

- **PDA interface**, powers and send data toward PDA. Programs supported:  
SeeYou Mobile, Winpilot Version 7 or higher, Navigator. **LX Mobile** is a PDA program special designed for LX 7007 users.  
Using of this solution will reduce time spend on manipulation dramatically.
- **User interface** powers and send NMEA at 4800, 9600, 19200 or 38400 bps
- **SD Card** interface make data transfer PC independent
- **IGC interface** to connect and power Colibri or LX 20. The connector pin out corresponds to the IGC standard and may be used to power the LX 7007 and to communicate with PC also, after using of standard Colibri Power adaptor. During training period this input can be used to connect Condor flight simulator.

**Options:**

- Integral **Flarm**, collision avoidance system
- **Remote** control, for both seats
- **Double seater** configuration
- **Compass**
- Secondary **LCD vario** indicators
- **Voice Module**, to express information and warnings by voice

**Simulator input for pilot training:**

- Condor PC flight simulator ([www.condorsoaring.com](http://www.condorsoaring.com)) data can be received via PC or IGC port after input of suitable passwords (See capture Passwords). Using of Colibri power adapter (Ord. Nr. COL 001) will make this job very simple. The adapter will power LX 7007 and also connect LX 7007 to your PC. LX 7007 original wiring can be also used. This feature is extremely useful for the pilots who want to learn about LX 7007 and also like refreshment after winter period. It is to point out that the altitude data will be send from simulator, means real final glide training will be possible.

## 1.1 Technical data

- Power input 10-16 V DC
- Consumption: 210 mA @ 12V (without audio and options), 260 mA with Flarm option
- 80mm (3") standard Aircraft cut-out for LX 7007 DU
- 57mm (2 1/4") standard Aircraft cut-out for LX 7007 AU Lgth 120 mm (incl. connector)
- Three physically separated com. Ports:
  - PDA port with 5V power supply delivers NMEA and task data for PDA and connects LX 7007 with PDA by data transfer
  - PC port (for PC communication)
  - IGC com port with IGC standard connector, suitable to connect Colibri or LX 20 or PC
  - User port for GSM Modem connection
- Drives following PDA programs: SeeYou Mobile, LX Mobile, Navigator, Winpilot....
- PDA data exchange with ConnectLX, ConnectMe, Navigator
- 16 Channel GPS receiver
- Memory space to store the whole European airspace (up to 6 sections)
- SD card interface
- External speaker
- System bus enables connection a wide range of options
- Built in fuse to prevent damages in stead of a short on 485 bus
- Data compatible with LX 20 and Colibri
- IGC approved flight recorder
- Weight: apr. 800g

## 1.2 Options

Using of bus system a wide range of optional interfaces can be easily connected to the basic configuration, without any significant installation works. The LX 7007 system bus can be simple extended using of **485 splitting units**, which allow plug and play Connection of optional devices. Following units can be connected to LX 7007 system bus:

- Second seat device
- Remote control, for both seats
- Flarm option (integral part, not bus connected)
- Secondary vario LCD vario indicators (unlimited number)
- Electrical compass device
- Voice module

### 1.2.1 Double seater configuration

The unit installed in the rear seat of the glider, is powered and receives all necessary data from the main unit. The communication between both units is exclusively **via 485 system bus**. An automatic **TP and TSK update** will follow after each power on the airspace update is done on pilot demand. See LX 7007 D manual for details.

### 1.2.2 Remote control

An extremely ergonomic lather coated handle which includes **8 push buttons** to operate LX 7007 and also two additionally buttons with open wires. This two buttons can be used for instance as PTT for radio and SC/Vario changeover command. Using a double seater configuration, two remote units can be installed, to control front and rear seat separately.

### 1.2.3 Flarm

A completely Flarm compatible electronic is an integral part of LX 7007 DU, if ordered as an option. All necessary connectors are available on the rear side of the unit (Flarm update port, Flarm External Indicator, Flarm antenna), which guaranties minimum the same comfort like using of original Flarm devices. It is very important to point out that the whole system uses only one GPS receiver and therefore offers a low power solution. One Flarm External display is an apart of delivery, extension to second seat is possible.



## 2 System description

### 2.1 Rotary switches and keys (buttons)

The following controls are mounted on the front face of the LX7007 DU

- Four rotary selector switches
- Six push buttons

**Note!**

After program version 1.04 some push buttons can be used like multifunction keys. A short or a long press will activate different LX 7007 functions.

The LX7007AU is an indicator only and has no controls; the displayed information being controlled from the LX7000DU

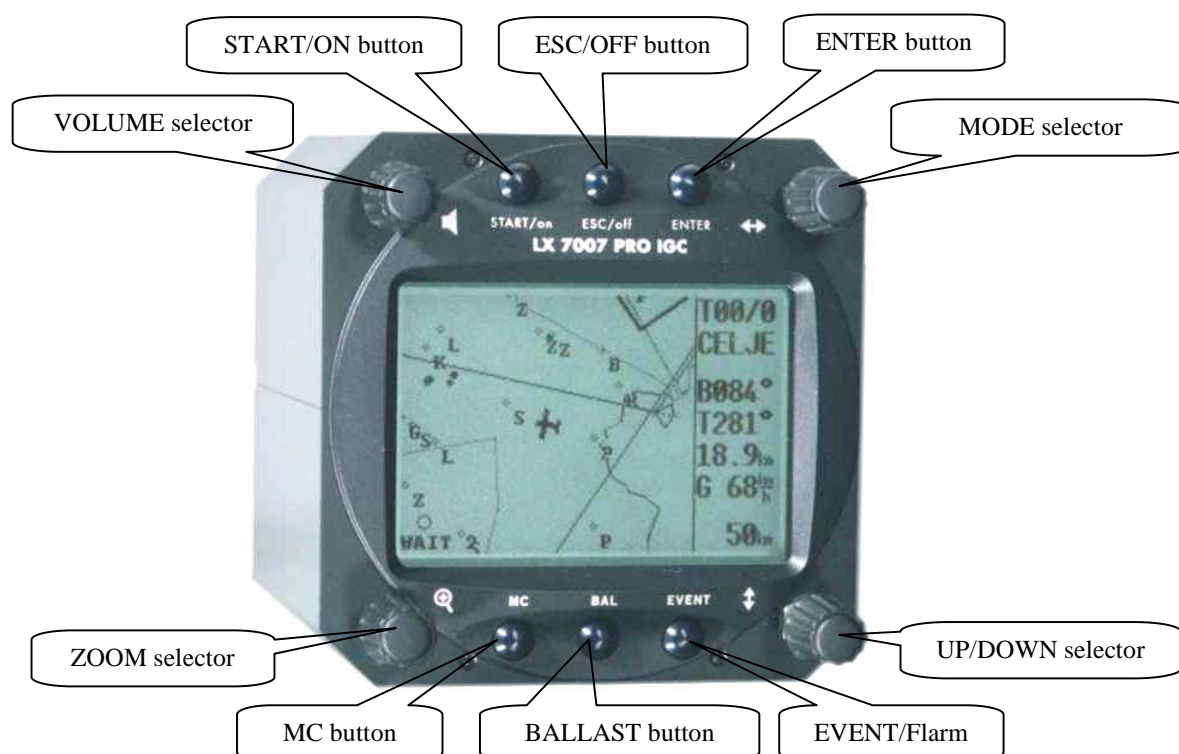

#### 2.1.1 ON/START button - Switching the Instrument ON and OFF

The **ON/START** button is multifunctional. If the instrument is not already powered up, a short press on the **ON/START** button will switch the instrument **ON**.

A **long press** on Start during task mode operation (apr. 6 sconds) will cause a jump to next , although the glider is not in the sector.

A **short press in TP mode** will set a position Marker, means will set an additionally point which coordinates corresponds the actual position of the glider.

**During edit** a short press on Start will move cursor one step back.

**Note!**

After the unit has received power a very typical message

**RESTORING**

**DATA**

will appear for approximately one second, **it isn't a failure report.**  
How to get the instrument ready for flying see capture 3.1.

To switch the instrument **OFF**, press the **ESC/OFF** button for a few seconds and the instrument will switch off. If an attempt is made to switch the instrument off during flight, the instrument requires confirmation from the pilot, **so the LX 7007 PRO IGC can not be switched off by mistake.** On powering the unit, the first screen shows the firmware version, database version, IGC coded serial number of the unit, and total memory in hours available for IGC flight records. After a few seconds, a second screen shows details of the glider and pilot.

Glider:  
**ANT. 18ST**

Pilot:  
**UROS KRASOVI**

The unit is equipped with a facility of storing up to 30 pilot names. If no names are stored, the unit shows the pilot name as UNKNOWN. By rotating the **UP/DOWN** selector, the display scrolls through the programmed pilots. Once the correct pilot is selected, pressing the **ENTER** button selects the airfield elevation screen and the current elevation should be entered, again using the **UP/DOWN** selector and the **ENTER** button. Similarly, the current QNH should also be entered. The airfield **elevation** input is **mandatory** while the **QNH** input **optional** (capture 3.1.2)

During flight the same button is used to **start the task, to see more characters of airport names and, in the edit menu, to go back one step** if an error has been made (see paragraph APT).

**Note!**

During flight, if main power is lost for a few seconds, **the flight recorder will not produce two flights.** The most important flight parameter, altitude will remain, which means that the final glide is not interrupted.

### 2.1.2 MODE selector (rotary switch) ⇔

The mode selector is used to change modes of operation. This switch has the **highest priority** in the system. Whenever it is operated, **a mode change will occur.**

### 2.1.3 AUDIO Volume selector

This knob is exclusively used to adjust audio volume.

### 2.1.4 UP/DOWN selector (rotary switch) ⇕

This rotary switch has a lower priority than the mode selector switch and is active all the time in the selected mode. It is mainly used for selecting sub menus during navigation and to scroll in the edit menu.

### 2.1.5 ZOOM Rotay switch

This is a multifunctional rotary switch. While its main function is to change the **zoom level in the graphic mode**, it can also be used as follows:

- To **select turn points** and **airports** when in the main TP page
- To **select task** when in the main TSK page
- If an error is made during editing, it is possible to **move the cursor** back by rotating this knob. This can only be done if 'editing' is active which is shown by the cursor blinking

### 2.1.6 ENTER button

The main function of this key is **confirmation**, and to **start edit procedures**.

### 2.1.7 ESC/OFF button

This is a multifunctional key, which has two main functions. If it is pressed and held for a few seconds, then the instrument will turn OFF as outlined in para 2.2.1 above.

If a press is made, then the button has the following functions:

- The display will jump to the menu of the next higher level (in edit only)
- During alpha-numeric input with the cursor active (blinking), **ESC confirms the whole line** (It is not necessary to press ENTER few times)
- Some special functions can be activated using ESC as described in subsequent paragraphs

### 2.1.8 EVENT button

Activates so called event function of flight recorder.

Event is a multifunction button, a short press will activate **Flarm traffic information page** and a longer press (apr.2 seconds) will activate flight recorder **Event function**.

### 2.1.9 MC and BAL buttons

Pressing these buttons activates the Mc Cready (MC) and ballast setting as shown below. The value is then changed with the UP/DOWN-selector. There is no secondary function of these buttons.

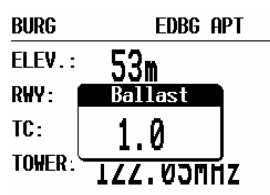
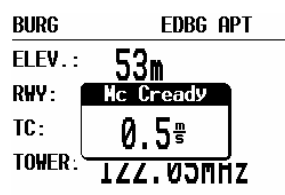

A **long press** on BAL will activate a **short cut to task edit** and a long press on MC will activate setup,. This function is active only in **Competition mode**.

## 2.2 Operating modes

The LX 7007 PRO IGC has 7 modes or main menus. All of them are selectable **directly by rotating the MODE switch**. The diagram shows the menu (mode) structure of LX 7007 PRO IGC.

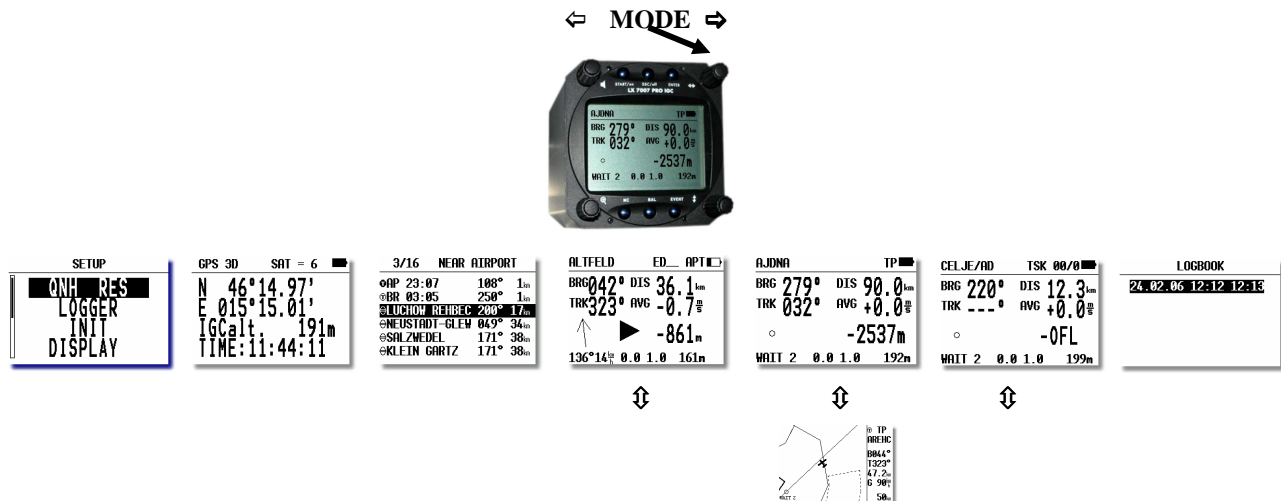

Navigation menus (APT, TP and TSK) have sub menus, which can be selected using the **Up/Down** rotary switch.

- GPS**                    **GPS status**, no inputs possible
- NEAR**                **Near airport**, select one airport or land able turn point of interest, no further inputs are possible
- APT**                   **Navigation and selection of airports**
- TP**                    **Navigation, selection and editing of turn points**
- TSK**                   **Navigation, selection and editing of tasks**
- STAT**                **Flight statistics and logbook**

**SETUP** has two levels. The first level enables direct input of individual parameters. After enter into SYSTEM SETUP global parameters can be adjusted.

**Note!**

After activation of **Competition Mode** only three modes are available, TSK, TP and Statistics. See capture 2.3.

## 2.3 SETUP

The SETUP is divided into two parts, **First level** (non system data) and the **Second level** (system data). The inputs done in the first level are connected with daily work around and the settings included in the second level may change system characteristics significant.

### 2.3.1 SETUP (First level)

All options are selected with the UP/DOWN switch and can be entered at any time; they contain **no system settings**.



**Note!**

TRANSFER offers no inputs, but enables data transfer LX 7007 to SD Card, PDA, Colibri or PC.

Once the desired option has been selected, press **ENTER** to access the sub-menu.

#### 2.3.1.1 QNH RES (QNH and Safety Altitude input)

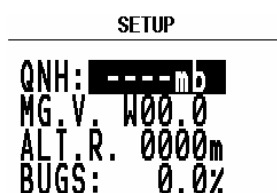

Input Procedure:

- Use the **UP/DOWN** selector to choose the item it is required to change (QNH, MG.VAR, ALT.R. or BUGS)
- Press **ENTER**
- Use **UP/DOWN** to select the value required and press **ENTER** to input it
- Once all changes are complete, press **ESC** top return to SETUP menu

**QNH:** Using this feature it is possible to **offset the altitude** datum, which could have changed due to pressure changes during the flight. During the initial power up sequence, an option to enter the QNH was presented. If the **actual QNH** was entered at that stage, then this feature is active. If the QNH feature was 'stepped over' during power up, then this function **is not active**. As changing the QNH influences the indicated altitude, care should be taken when changing the value as an incorrect setting can upset the final glide calculation.

**MG. V.** If the GPS receiver calculates **magnetic variation** then AUTO will be displayed here and no input is possible. If AUTO is not displayed, then the GPS receiver is not calculating magnetic variation and it is obligatory to input the magnetic variation for the area being flown over. If this is not done, then all calculated winds and tracks flown will be true and not magnetic.

**ALT.R.** This setting is the **altitude reserve or safety altitude**, and is the height that the instrument adds to the final glide altitude required so that the glider arrives over the final glide destination at the selected safety altitude. After safety altitude input, the pilot has to keep final glide **indicator on 0** to arrive on safety altitude.

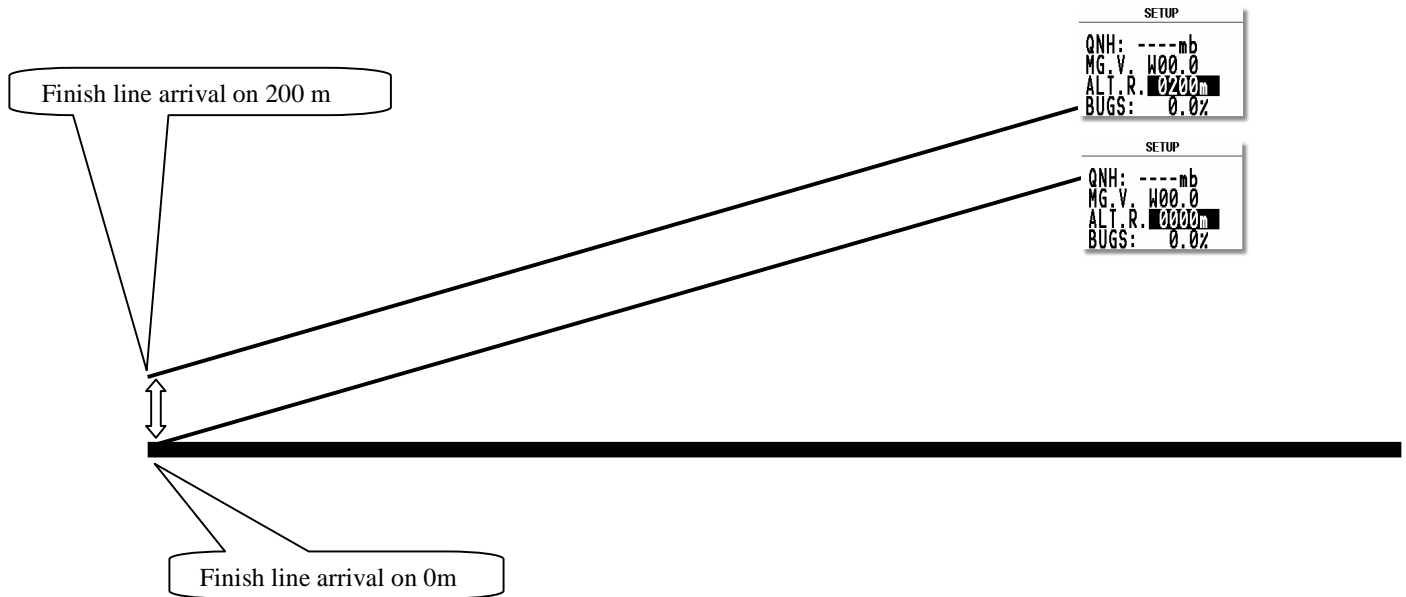

**Note!**  
The **safety altitude** setting will remain even after power off, only a new input can change this input.

**BUGS:** This sets the **polar degradation** because of “buggy” wings. The input is in percentage degradation of glide ratio. (5%, means glide ratio degradation is 5%)

**2.3.1.2 LOGGER (Input of flight recorder parameters))**

The flight recorder is fully approved by the IGC (A sub-committee of the FAI.) and will produce **secure flight records** that are acceptable for all FAI requirements including world records.

After selecting **LOGGER** and pressing **ENTER**, the following flight recorder settings are accessible.



**FLIGHT INFO** All important data, such as the pilot's name, glider type, glider registration, competition number and competition class can be entered. The data is entered with the **ENTER, UP/DOWN** and **ESC** routine. This data is subsequently written into the 'H' record of the IGC flight log. Alternatively, this data can be entered with a PC or via a Colibri or LX20 (see Chapter 4). All units having got SD Card Interface are able also to exchange flight info data (read and write) with SD card. Using of ConnectLX or ConnectMe PDA running programs will do the same job.

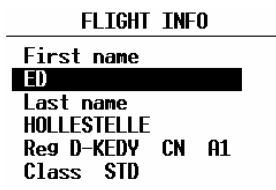

**Note!**

The instrument is capable of storing up to **30 different pilot's** names. Each pilot's name, which can be also password protected, can have different different (personal) settings. This is useful if one likes to fly with a custom polar, fly the glider in different configurations, or fly in decentralized competitions, Online-Contest, Barron-Hilton-Cup, etc. For more information on configuring pilot names see captures 2.3.2.8, and for setting custom polars 2.3.2.12.

Before leaving the FLIGHT INFO menu, the actual name can be saved into pilot list, if not already present.

**Note!**

If only **one pilot** flies the glider, then after entering his name, it is not necessary to enter it into the list. In the above screen 'N' should be selected to do this. The name will then appear automatically on instrument power up together with all the parameters that have been set. An exception to this is if he flies the glider in two different configurations; then he should list his name twice, e.g. once with a suffix of 15m and again with a suffix of 18m with **different polars** in each name.

**LOGTIME** is an important parameter as it shows the total memory available for recording the flight.

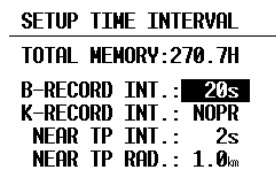

**TOTAL MEMORY** is the **capacity of memory** in hours that can be stored and only depends on the settings. It does not decrease as flights are stored and will only change after new settings have been made in the setup. **If the memory is full, the oldest flights will be overwritten without warning.** The total memory simply indicates how many hours of flight can be made without losing any flight data before overwriting occurs.

**B-RECORD:** This is the main IGC record in which position; GPS altitude, pressure altitude, UTC and GPS status are stored. The default interval is 12 seconds and it can be changed. As the interval is reduced, the Total Memory will be seen to decrease.

B record example:

B1024054344093N00547300EA0021100277035000 (time, coordinates, GPS status, pressure altitude, GPS altitude, ENL)

**K-RECORD:** This record can be used to store non-essential flight parameters and is not active by default. It should not be activated unless the IGC record format is fully understood. If required to be activated, the J-Record (see below) will select the flight parameters that are stored in the K-Record.

**NEAR TP INT:** This setting enables the fixing rate set by the B-Record to be increased close to a turn point to ensure that a fix is obtained in the observation zone.

**NEAR TP RAD:** This setting defines the radius from the turn point at which increased fixing rate is to start.

- (I) **RECORD:** This record permits additional flight parameters to be added to the B-Record. Except of FXA which should be always ON (IGC regulation).

SETUP I-RECORD		
TOTAL MEMORY: 101.8H		
FXA <input checked="" type="checkbox"/>	TAS <input type="checkbox"/>	TEN <input type="checkbox"/>
ENL <input checked="" type="checkbox"/>	HDM <input type="checkbox"/>	WDI <input type="checkbox"/>
VAR <input type="checkbox"/>	HDT <input type="checkbox"/>	WSP <input type="checkbox"/>
GSP <input type="checkbox"/>	TRM <input type="checkbox"/>	
IAS <input type="checkbox"/>	TRT <input type="checkbox"/>	

- FXA: current horizontal accuracy of GPS (**factory enabled**)
- VXA: current vertical accuracy of GPS
- RPM: engine RPM
- GSP: ground speed
- IAS: indicated airspeed
- TAS: TAS
- HDM: mg. heading
- TRM: magnetic track
- TRT: true track
- TEN: total energy
- WDI: wind direction
- WVE: wind
- VAR: vario
- ENL: engine noise level (**factory enabled**)

Each setting activated will reduce the **total memory capacity**. All together up to **four items** can be enabled.

**(J) RECORD:** The J-Record defines the flight parameters that are to be stored in the K-Record. These parameters are the same as those used for the I-Record. Using this record will reduce the total memory **by about half**.

**Note!**

Unless the user has a good understanding of the composition and use of IGC flight records, then it is recommended that, other than the ENL, no alterations are made to the default selections.

**EVENT** This option programs what happens on pressing the **EVENT** button. On pressing the button (proximally 2 seconds), the flight recorder places a special marker, called a PEV (Pilot Event), in the IGC flight record. At the same time, it causes the recorder to run at a different fix interval for a certain time. The interval and time are set up in this option. Competition rules may require the **EVENT** to be activated at some stage during the flight.

SETUP EVENT MARKER

FIX INTERVAL: **2s**  
NUMBER OF FIX: **30**

**Example:**

The setting above will cause the recorder to log 30 additional fixes at 2-second intervals on pressing the **EVENT** button.



### 2.3.1.3 INIT (Input of variometer parameters)

The following parameters can be set using this option.

```

INITIALIZE
VAR.FIL: 2.0 S.V. OFF
VARIO INT.: 20s
VARIO RNG.: 5%
TAB: 1.0% ETA: GS
AUTO SC: OFF
WIND/COMPASS: N.C.

```

- VARIO FIL: This sets the time constant of the vario from 0.5sec up to 5 sec; the default setting is 2.0 sec
- S.V. S.V. means Smart Vario, giving four levels of dynamic damping of the vario indication and off. See chapter 2.5 for details
- VARIO INT: This setting defines integration period for the average in seconds; the default is 20 seconds
- VARIO RNG: This sets the full scale range of the vario
- TAB: This setting defines the width of the audio dead band in speed to fly mode
- ETA: This setting selects the parameter, **GS (ground speed), VAR or MC**, that is used to calculate the **Estimated Time of Arrival**. When flying a programmed task, the calculation takes account of the unflown portion of the task, around any TPs or APTs not yet reached

**Note!**

Suggested setting for competition pilots is VAR or MC.

**GS**, bases ETA on the achieved groundspeed along track. It takes into account differences between bearing and track of up to 90°. If the difference is greater than this, --:-- is displayed.

**VAR** is based on the achieved average thermal climb rate and assumes that this is going to continue.

**MC** is based on the actual Mcready setting.

**Note!**

All three methods of calculating ETA and ETE (**E**stimate **T**ime of **A**rrival, **E**stimate **T**ime **E**lapsed) take into account glider altitude, wind and safety (arrival) altitude, thus ensuring that the calculation made is the best available

- AUTO SC: This option defines the conditions by which the instrument is switched automatically between vario and speed command  
**OFF**: Switching is possible exclusively by an external switch, connected to the LX 7000 AU unit  
**GPS**: When the **GPS detects** that the glider is circling an automatic change over to vario will happen, after approximately 10 seconds. Detection of a straight flight will cause a change over to speed command.

**TAS**: When the **TAS exceeds** a pre-set value. The TAS at which switching occurs can be selected in 5 km/h steps from 100 up to 160 km/h (or the equivalent in knots or mph)

**Note!**

The external switch wired to LX 7007 AU has absolute priority and will override all other switching methods.

- WIND/COMPASS: N.C. means compass option not connected. When the optional compass module is installed, the instrument uses magnetic track to make an additional wind calculation. The calculation requires the glider to **fly straight a specified period**, which is set in this option. The default is 15 seconds, but the longer the period, the more accurate is the calculated wind.

### 2.3.1.4 DISPLAY

This option sets the contrast of the LC display. The actual contrast can vary with viewing angle, ambient light level and temperature. The contrast is changed by rotating the **UP/DOWN** selector.

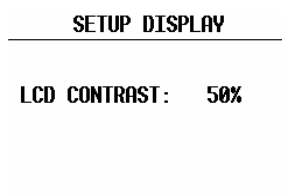

Default contrast setting is 50%, a new setting will remain after power off.

**Note!**

Operation under extreme temperatures may need some contrast adjustments done by pilot.

### 2.3.1.5 TRANSFER

This option initiates the transfer of data between the instrument and a connected PC, PDA, LX 20 / Colibri, or SD Card. Data transfer procedure is started by pressing **ENTER** with **TRANSFER** selected.

A dialog will open and the pilot has to select an option of his interest. About details see capture 4.

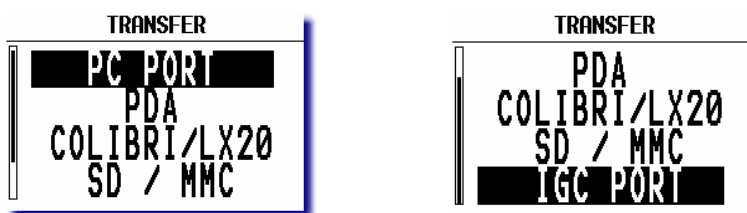

**Note!**

After **ENTER** on **PC PORT** the communication LX 7007 – PC via **5P connector** usually mounted on the instrument panel will be possible. After enter on **IGC PORT** a PC communication via **IGC port** after using of a standard IGC cable will be possible.

After **PDA activation** data exchange LX 7007 – PDA will be possible, suggested program is ConnectLX/ConnectMe, available on [www.lxnavigation.si](http://www.lxnavigation.si) or [www.naviter.si](http://www.naviter.si).

**Note!**

PDA port is delivering extended NMEA data sentences. This data include also Flarm collision relevant data at **19200 bps** to drive PDA (SeeYou Mobile, LX Mobile, Navigator, Winpilot...).

After Enter on **Colibri/LX 20**, the data exchange with eventually Connected Colibri or LX 20 device will be possible (read/write TP&TSK, read/write flight info, read/write zones). Connector marked as IGC should be used; all necessary cables are delivery included.

**Note!**

As mentioned before, all three communications ports are physically separated and therefore no data collision problem could occur, even all external devices connected and on.

**SD/MMC selection** will arrange data exchange LX 7007 – SD memory card.

**IGC port** will offer a PC communication via any IGC compatible cable. A suitable solution is LX AC power supply (Ord. Nr.: COL-AC-PC), which will power LX 7007 at the same time.

### 2.3.2 COMPETITION Mode

This menu makes possible to enable or disable Competition mode of operation. After Competition mode has been selected only **3 operation modes** will be available. This relieves the pilot during competition flight significant.

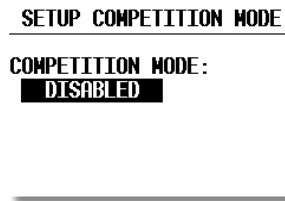

A **short cut** via MC long press will activate Setup. Functionality of all three mentioned modes remains during Competition mode unchanged.

### 2.3.3 SYSTEM SETUP (Second level)

After entering the System Setup, a further 28 system settings are available.

#### 2.3.3.1 AS SELECT (Selection of airspace section)

The unit is capable to store up to **6 sections** (0 up to 5) of airspace, which means practically the whole European airspace. The unit is delivered fully loaded. Selection of suitable area should be done by pilot using of this menu. Countries included in the section are readable on the display, \* means a partly covered country.

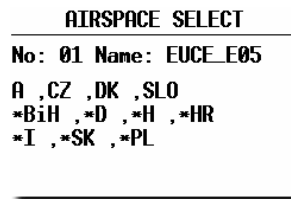

**Note!**

To reload a new airspace section (.CUB format only) is done simple by overwriting of an actual active airspace using of LXe PC program, **or SD card**. See capture 4.1.1.

**Note!**

To prepare custom airspace, in .CUB format, use our special tool for airspace creation and edit, called LxAsbrowser, available for free on [www.lxnavigation.si](http://www.lxnavigation.si) or on LXe CD.

**Note!**

Activation of any airspace section stored in the LX 7007 memory is possible any time, also during flight.

If two seater configuration is used, after each change of airspace section on master an update for second seat will be offered.



**Escape** will cancel update of second seat unit.

**2.3.3.2 VOICE MODULE**

LX Voice Module is a LX system bus participant and receives data and power via bus. Configuration LX 7007 with Flarm option and Voice Module needs additionally a direct connection LX 7007 Flarm output to LX Voice Module Flarm input (see also LX Voice Module manual). A suitable data splitter is LX Voice Module delivery included. Voice module is 100% controlled through LX 7007 after using of settings which are described in this menu.

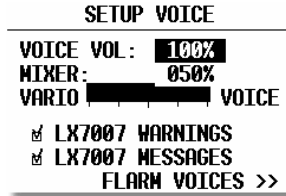

**VOICE VOL** : sets volume (loudness) of expressed voice information (LX 7007 and Flarm)

**MIXER** : defines percentage of vario volume reduction during Voice Module active time

**LX 7007 Warnings:** if checked all warnings generated by LX 7007 will be expressed by Voice module (for instance check gear, airspace...)

**LX 7007 Messages:** if checked all information generated by LX 7007 will be expressed by voice (for instance set elevation.....).

VOICE	W/I	DESCRIPTION
APPROACHING TO FINAL GLIDE	I	Remembers approximately 150 m before reaching final glide, active in TSK only
FINAL GLIDE ESTABLISHED	I	Remembers reaching final glide, active in TSK only
APPROACHING TO AIRSPACE;	W	Warns about AS proximity
WARNING ALTITUDE	W	Warns before reaching of daily altitude limit
TASK DECLARED	I	Informs after successfully task declaration procedure
NO RESPONSE FROM ANALOG UNIT	W	Message that vario unit isn't connected
LOW BATTERY	W	Low battery voltage presence
EVENT MARKED	I	After event marker activation
CHECK LANDING GEAR	W	After (glider altitude) – (nearest airfield elevation) = 200m or less
NEAR ZONE	I	Informs about near to obs. zone of TSK (Logger/Logtime/near TP)
NEAR	I	Informs about near to TP or APT (corresponds on setting Syst.Setup/TP)
INSIDE ZONE	I	Informs about inside zone position (TSK)
OUTSIDE ZONE	I	Informs about outside zone position (TSK)
NEXT	I	Expressed after change over to next TP (TSK)
TASK STARTED	I	Informs that task has been started (TSK)
SET ELEVATION	I	Requests set of airfield elevation
SET QNH	I	Informs about possibility to set actual QNH
SELECT PILOT	I	Informs about possibility to select a pilot
TWO MINUTES	I	Informs that the glider position is two minutes in front of finish (TSK)
STALL	W	After IAS will go lower than set (Syst. Setup/Input)
CHECK GEAR	I	Remembers 15 minutes after take off

Table of LX 7007 generated voices

I = information W= warning

**FLARM VOICES** setting will appoint voices related to Flarm.

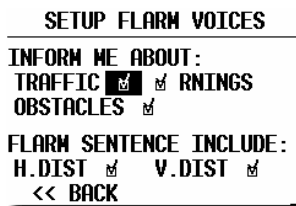

The pilot is able to adapt Flarm voices to his personal requirements. Checked () items will be active and vice versa. A Flarm report always consists of:

**Description** (Traffic, Warning, Obstacle) **Direction** (XX o'clock)

Two additionally information about horizontal and vertical distance (above below) will be expressed if checked.

### 2.3.3.3 TP (Turn point)

All settings concerning turn points can be done in this menu. The LX 7007 PRO IGC is able to store **maximal 600 turn** points in a proprietary format (\*.DA4).

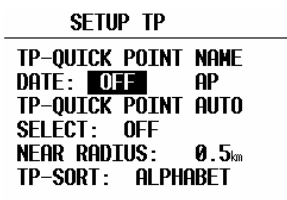

#### TP-QUICK POINT NAME

The pilot is able to store his **actual position** during the flight by pressing the **START** button in **TP** mode in the **first (upper) navigation page** (see Para 3.2.4.7). These turn points are called QUICK TP and are given the default name **AP** (actual point) and time, for instance AP 12:55. Such a turnpoint will disappear after power off, as they are stores as markers. To convert marker into a real turnpoint use TP edit.

#### Settings:

**DATE: OFF** stores the position as **AP: hh:mm**. The numbers are the time that the TP was stored.

**DATE: ON** stores the position with the date and time (**dd,mm,hh,mm**), for instance **2812130 for 28 Dec. 13:30**).

#### TP-QUICK POINT – AUTO

When **SELECT: OFF** is active, the actual position **will not** be selected automatically and immediately ready for navigation

When **SELECT: ON** is selected, the actual position point will be selected automatically and ready for navigation in TP menu.

#### NEAR RADIUS

The setting has nothing to do with the setting described in capture **LOGGER**. The LX 7007 PRO IGC has a very useful feature named “**Simple task**” which is active when a regular task is not set or not started. When the instrument detects that it is within the **Near Radius** of a turn point or airport, then that turn point can be treated like a confirmed TP of a simple task. Naturally the turn point or airport should be selected and ready for navigation during Near Radius retain time. This gives the ability to provide in-flight statistics for subsequent evaluation without setting a full task. For more information on this feature see Chapter 3.4, flying with the LX 7007 PRO IGC.

#### TP-SORT

The LX 7007 PRO IGC is able to sort the turn points **either alphabetically** or **by actual distance** from the momentary position. If sorted under distance **the nearest TP** will be the first to be displayed when selecting the turn points.

### 2.3.3.4 OBS. ZONE (Observation Zone)

This menu defines point sector geometry and **relates only points of tasks.**



The following items can be chosen:

- The **START ZONE**
- The turn **POINT ZONE**
- The finish line (**FINISH ZONE**)
- **TEMPLATES**
- **RESTORE ALL**

Every **observation zone (START, POINT, and FINISH)** is defined with **two angels, two radius and orientation**. Using of these parameters makes possible to create any known zone geometry, separately for start, turn point and finish. **All tasks** stored in LX 7007 will match this **“global”** settings, an exception are so called **AAT tasks**.

The **TEMPLATE** activation will set all zones (sectors) to 500 m cylinder or FAI foto sector. Means the **“global”** zones of all already programmed tasks will be adequate modified.

LX 7007 also supports so called Assigned Area Task (**AAT**). Additionally, **up to 5 (five)** tasks can have individual sector geometries defined, **even for a single turn point of one task**. This is done using the **“local”** settings in the corresponding task in the task menu. These local settings are done in the same way as described below but their incorporation in a specific task is covered in Para 3.2.4.

**Note!**

The **“global”** sectors (zones) will always match settings defined in SETUP/ OBS ZONES, the **“local”** sectors will correspond to the individually set parameters. Local sectors are set exclusive after using of ZONE function in TSK edit..

**Note!**

After programming **'local'** sector geometries in specific tasks, those sectors will remain unchanged after application of TEMPLATE or changes of Start, Point or Finish in OBS.ZONES will happen.

**RESTORE ALL** will set **all sectors** doesn't matter **“local”** or **“global”** corresponding to the momentary active settings of START, POINT and FINISH.

2.3.3.4.1 START ZONE

To define the start zone geometry, select **START ZONE** and press **ENTER**:

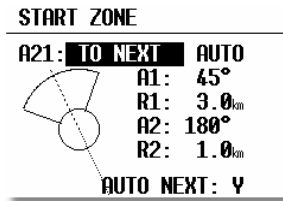

Example of most sophisticated zone where both angles and radius are used

- A21: Orientation options: **TO NEXT**, **RAD.1**, **TP**, and **USER VALUE**). If **TO NEXT** or **RAD.1** are selected, then **AUTO** is also displayed not permitting any rotation. If **USER VALUE** is selected, the sector can be rotated.
- A1: First angle
- R1: Radius of the sector having angle A1, e.g. 3km for the FAI photo sector.
- A2: Like A1, used for creating combined sectors.
- R2: Like R1, also used for combined sectors
- AUTO NEXT (Y, N) defines the change over to next point procedure on reaching the sector.

**Note!**  
Start point AUTO NEXT setting is default N.

At first, this sounds complex, but the following examples will help to clarify the meaning of these settings.

**Example 1:**

The default setting shown above defines the FAI 90° photo sector combined with a 1km radius cylinder. To modify these settings to set the FAI 90° photo sector as the start zone, the parameters are modified as follows:

**A21** is set to **TO NEXT POINT** and **AUTO** as the start zone wants to be orientated symmetrically about the track to the first turn point.

**A1** is 45°, because the bisector of the FAI 90° sector is needed.

**R1** is 3km, the radius of the sector.

**A2** and **R2** are both 0 as a combined sector is not needed.

**Example 2:**

Program a 180°, 6km Start Zone:

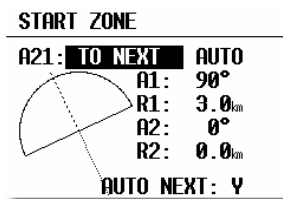

A21: **TO NEXT POINT** and **AUTO**

A1: 90° bisector

R1: 3km radius

A2: 0

R2: 0

Other possible options for the setting of **A21** are:

- **RAD.1.TP:** This type of start sector was used in the 1999 World Gliding Championships in Bayreuth. A radius is drawn from the first turn point, through the start point and a second, greater radius is drawn, thus creating a radial segment of defined length orientated symmetrically about the start point. The advantage of this system is that a pilot starting at the extremity of the sector has to fly the same distance to the first turn point as a pilot starting directly over the start point. This refinement compares with the classical start line where the distance to the first turn point is increased the further one starts from the centre of the line.

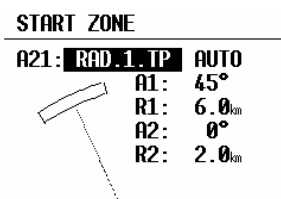

**A21:** **RAD.1.TP** and **AUTO** are selected

**A1:** This setting is ignored; only R1, which defines the length of the segment, is relevant

**R1:** Set to 6km, the half-length of the segment, giving a total segment length of 12km

**A2:** Again, this setting is ignored

**R2:** This sets the length of the two truncated radials that define the edges of the start sector. The setting is 2km in this example

- **FIXED VALUE:** This setting allows the bearing of the bisector to be rotated so that it is no longer aligned with the track to the first turn point. The required bearing is entered in **A21** after **FIXED VALUE:**. This option is rarely used for start sectors, but is often used for finish zones which may require to be orientated to a particular runway (see "FINISH ZONE").

#### 2.3.3.4.2 POINT ZONE

This setting defines the turn point zone, sometimes referred to as the observation zone. The procedure is very similar to setting the **START ZONE** except that more options are available for **A21**.

- **SYMMETRICAL:** The axis of the turn point zone is orientated symmetrically about the line bisecting the inbound leg from the previous turn point and the outbound leg to the next turn point.
- **TO PREV POINT:** The axis of the turn point zone is orientated towards the previous turn point. This option is intended for Cat's Cradle and related tasks.
- **TO NEXT POINT:** The axis of the turn point zone is orientated towards the next turn point. This option is also intended for Cat's Cradle.
- **TO START POINT:** The axis of the turn point zone is orientated towards the start point. Again, this is a Cat's Cradle option.
- **FIXED VALUE:** The axis of the turn point zone can be orientated in any specified direction. This is the only option for which **A21** is not set to **AUTO**.

#### Example 3:

To specify a turn point zone that is a combination of the FAI 90° photo sector and a 500m radius cylinder:

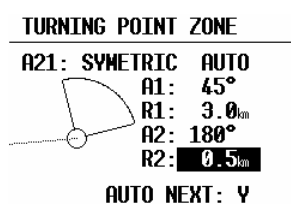



**HDG:** SYMMETRICAL  
**A21:** AUTO  
**A1:** 45°  
**R1:** 3.0km  
**A2:** 180°  
**R2:** 0.5km

**Note!**

It should be noted that when defining combined sectors, the sector with the smaller radius must be designated by A2 and R2 (ie.  $R1 > R2!$ ).

**Note!**

While the combined sector is used in many National competitions, it is emphasised that for record flights, FAI badges, 1000/2000km-diplomas and for the Barron-Hilton-Cup, only the FAI 90°-photo sector is valid!

**Note!**

AUTO NEXT will go automatically to N, if R1 will be chosen bigger than 10 km, AAT is expected.

**2.3.3.4.3 FINISH ZONE**

This setting defines the **FINISH ZONE** or Line. Highlight the **FINISH ZONE** with the cursor and on pressing **ENTER**, a similar screen as for the previous settings is displayed, except that there are only two options for A21:

- **TO LAST LEG:** The axis of the FINISH ZONE is orientated directly back to the last turn point. This is the conventional setting for National competition flights.
- **FIXED VALUE:** The axis of the FINISH ZONE can be orientated in a specified direction (see example 4).

**Example 4:**

It is required to orientate the finish line perpendicular to the runway 06/24, which is not related to the bearing to the last turn point:

**A21:** Select FIXED VALUE and then enter either 060° or 240°, depending on the direction of the final glide. For example, if the final glide were in direction 240°, then 060° would be entered. The “flat side” of the sector is now directed back to the last leg and the glider will cross the line to enter the sector.

**A1:** 90°  
**R1:** 1.0km  
**A2:** 0 (not programmed)  
**R2:** 0 (not programmed)

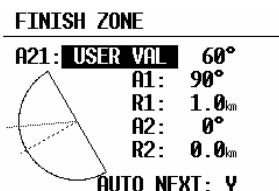
**Note!**

There are many ways to complete a flight. For instance, when completing flights for FAI badges or diplomas, it is enough to land inside the airfield boundary if the airfield is the finish point. If a remote finish point is specified, then the appropriate sector must be used. If in doubt, consult the competition rules of the FAI Handbook as appropriate.

### 2.3.3.4 Using of LXe for zone preparation

All possible zone geometry settings can be prepared in LXe PC program (ZONES) and easily transferred to the LX 7007.

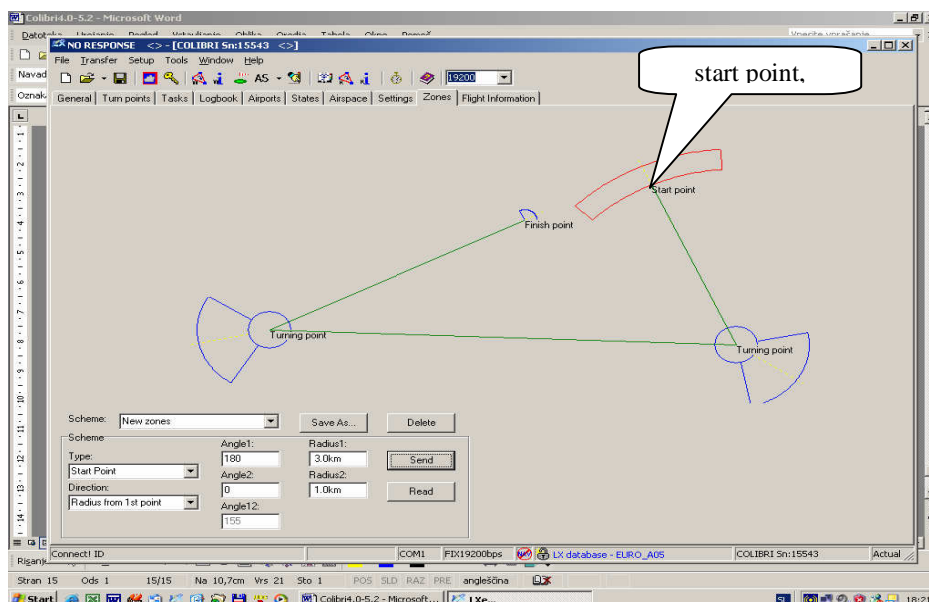

After data transfer all global setting will be changed.

### 2.3.3.5 WARNINGS ( Airspace Penetration and Height Warnings)



#### 2.3.3.5.1 Airspace Warnings

The LX 7007 pro IGC monitors the glider's position both horizontally and vertically in relation to airspace, and will give both an acoustic and visual warning prior to the airspace being penetrated. The warning will be activated a specified number of seconds before entering the airspace – **Warn me xxx seconds before**, where XXX is the desired input between 20 and 600 seconds. The default value is 120 seconds. When thermalling, the wind vector is used to calculate the horizontal warning and the achieved climb rate used to calculate the vertical warning. The warning calculation takes into account the specified lower and upper airspace heights and no warning will be given if the predicted flight path is over or under the airspace height limits. The airspace zones for which warnings are required are set by placing a tick in the appropriate box as shown below.

#### Note!

Setting “Warn me 120s before” will warn the pilot that the glider will hypothetical enter the airspace in two minutes provided that the horizontal and vertical speeds are not changed.

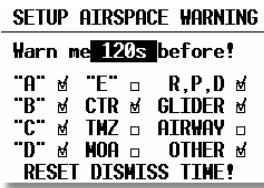

Checked airspace (✓) will cause warnings to be given, and vice versa. Airspace is selected according to the ICAO airspace classifications of A to E. In addition the following other airspace areas can be selected

- CTR control zone
- MTZ mandatory transponder zones
- MOA military operating area
- R,P,D restricted, prohibited, dangerous zones
- GLIDER glider activity zones
- AIRWAYS airways
- OTHER

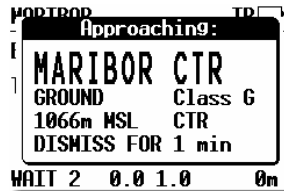

Example of an airspace warning screen

The **DISMISS** can be used to **deactivate** the particular airspace warning for a period of time. Use the **UP/DOWN** selection to enter the duration for which the warning is required to be deactivated and press **ENTER**. The displayed airspace warning can be **dismissed** from 1 minute to permanent de-activation (**ALWAYS**). **DISMISS** selections can subsequently be cancelled.

**Note!**

Use the **DISMISS** function to temporarily **deactivate** individual airspace warnings. All warnings can be reinstated using the **RESET DISMISS TIME** command in the **SYST. SETUP/WARNINGS** menu.

**2.3.3.5.2 Detailed AS screen**

After press on **ESCAPE** during the **airspace warning** presence, the unit will change over into specific graphic screen (**Detailed AS screen**) which enables to fly extremely close to the airspace border. In this configuration the **horizontal or vertical distance** (depends on glider position) to the particular airspace will be continuously present on the display. If a **Voice Module Option** is installed a voice information will also follow.

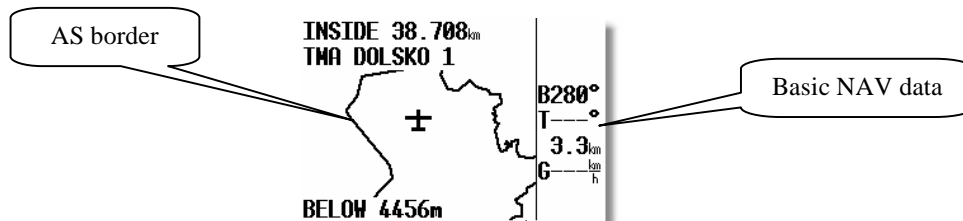

Example of a Detailed AS screen

Use **ESCAPE to exit**. If there is a need of re-enter into the detailed screen after the pilot has already exit, use ENTER and select **MRU ZONES** in APT, TP or TSK. The last AS zones which caused a warning will be listed.

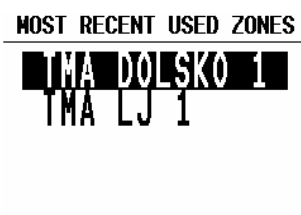

Example of MRU screen

### 2.3.3.5.3 Altitude Warning

Altitude warnings can be setup in a similar way and inform the pilot that he is approaching pre-selected altitude limits.



The warning altitude is always above MSL (Mean Sea Level). The warning will be activated at a specific time before reaching the altitude limitation. While thermalling, the achieved climb rate is used to calculate when the warning altitude is going to be reached and similarly, in straight flight, the descent rate is the controlling parameter. Operation of the altitude warning is the same as for the airspace warning and use of the DISMISS and RESET DISMISS TIME commands are identical.

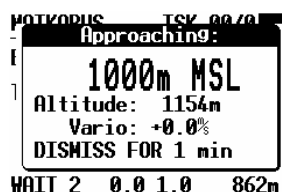

Example: altitude warning

### 2.3.3.6 GPS (UTC offset and earth datum)

**UTC:** A UTC offset can be entered at this option, thus ensuring that all time references are to local time rather than UTC. However, it should be remembered that any offset will have no effect on the time recorded in the IGC flight log; this will always be UTC

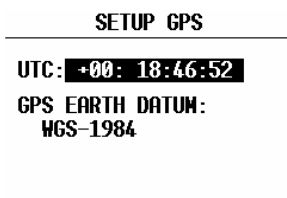

**GPS EARTH DATUM:** It is not possible to change the GPS earth datum. IGC regulations require that all flight recorders use the **WGS84** earth datum.

### 2.3.3.7 UNITS

All known units and combinations thereof can be programmed in the LX 7007 PRO IGC. The various units that can be selected are outlined below:



- LAT/ LON: degrees and decimal minutes; or degrees, minutes and seconds
- DIST: kilometers (km); nautical miles (NM); or statute miles (ml)
- SP (Speed) kilometers per hour (km/h); knots (kts); or statute miles per hour (mph)
- VARIO: meters per second (m/s); or knots (kts)
- HDG: degrees magnetic ( °M) or degrees true (°T)
- WIND: kilometers per hour (km/h); knots (kts); miles per hour (mph); or meters per second (m/s)
- ALTITUDE: meters (m); or feet (ft)
- QNH: millibars (mb); millimeters of mercury (mm); or inches of mercury (in)
- LOAD: **Overload**; kilograms per sq meter (**kg/m<sup>2</sup>**); pounds per sq foot (**lb/ft<sup>2</sup>**); **kg, or lbs**

**Note!**  
After using of **kg or lbs** input, obligatory complete settings in capture 2.3.2.14 (LOAD).

$$\text{OVERLOAD} = \frac{\text{Glider + Pilot + Ballast}}{\text{Glider + Pilot}}$$

**Example:**

An overload of 1.2 means that the current ballasted flight weight is 20% higher than the unballasted flight weight.

### 2.3.3.8 GRAPHIC

The graphic display of the LX 7007 PRO IGC can show a lot of information and if it is all selected, the display can become very cluttered. This particularly applies to airspace information and the user should ensure that only relevant airspace is selected. It should also be remembered that a cluttered display also increases the load on the graphical processor and slows down the rate at which the screen is redrawn.

#### 2.3.3.8.1 SYMBOL

The LX 7007 PRO IGC graphic display supports three sizes of glider symbol; **large, medium and small**. Rotate the **UP/DOWN** selector to select the corresponding glider symbol. **TAIL LENGTH** enables a 'mouse droppings trail' to be configured that will display the achieved track for the last x minutes. The trail is disabled if the time period is set to zero.

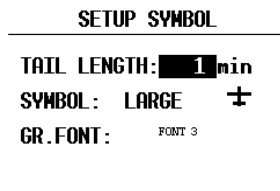

The user is able to select between four different **sizes of fonts**, this selection will influence on characters in graphic navigation pages only.

**2.3.3.8.2 AIRSPACE (Graphics)**

This setting allows the pilot to define which airspace types will be **shown on the display**. Each airspace type can be set to **ON**, **OFF** or a **ZOOM range** beyond which the particular airspace will not be displayed. Selecting **ON** will always show the airspace regardless of the ZOOM setting, and **OFF** will never show the airspace. If all airspace is set to **ON**, then at large ZOOM ranges, the screen becomes very cluttered and the graphics processor will become overloaded and slow down. To prevent this happening, the ZOOM range option allows a range to be set, beyond which the airspace will not be displayed.

SETUP AIRSPACE		
"A"	<b>100<sub>km</sub></b>	R,P,D 100 <sub>km</sub>
"B"	50 <sub>km</sub>	GLIDER 100 <sub>km</sub>
"C"	100 <sub>km</sub>	TMZ 50 <sub>km</sub>
"D"	100 <sub>km</sub>	MOA 50 <sub>km</sub>
"E"	20 <sub>km</sub>	AIRWAY 50 <sub>km</sub>
CTR	ON	OTHER 100 <sub>km</sub>

Class A will only be shown when the ZOOM scale is 100km or lower

**Note!**

If, for instance, 100 km is selected, then the airspace will only be shown when the ZOOM range is 100 km or lower. When the ZOOM range is greater than 100 km, the particular airspace **will not be shown**.

The LX7000 allows the following types of airspace to be shown:

- Class A
- Class B
- Class C
- Class D
- Class E
- CTR. Control zone
- R,P,D Restricted, Prohibited and Danger areas
- GLIDER
- TMZ Transponder mandatory zones
- MOA Military operating areas
- AIRWAY
- OTHER

**Note!**

CTRs are marked using a bold line, so the pilot is able to separate CTRs from other airspace very quickly.

• **Airspace Customizations**

A completely new feature of the LX 7007 pro IGC is that pilots can customise their own airspace files. Pilots are able to create areas, or to add and remove particular airspace according to their personal requirements. All customisation is done using the well known "Open Air format" or "Tim Newport Piece format". Detailed instructions on customisation are described in a separate document, the **LxasBrowser manual**. This manual is supplied with each instrument and is also available on [www.lxnavigation.si](http://www.lxnavigation.si). Restricting the creation of airspace to a dedicated area where the pilot is usually flying will make the instrument much faster when operating the ZOOM function.

**Note!**

All airspace files used with LX7007 must have the **.CUB** extension; it is not possible to load old airspace format files. The new airspace files can be created and loaded using Lxe build July 15th 2003 or later.

**Note!**

To be able to use all the benefits of the airspace graphics and warnings, it is recommended that some time is taken to study the airspace of the task area. All irrelevant zones should be deleted so that the speed of graphical presentation remains fast and unnecessary airspace warnings are avoided. Some TMAs are built from many sectors and is recommended that these sectors are amalgamated into one large TMA definition, if possible. After modification of .LXW files it is essential that a new .CUB file is built. LXW is a new airspace data base format described in the LxasBrowser manual or on the [www.lxnavigation.si](http://www.lxnavigation.si) website.

**2.3.3.8.3 APT (Graphics)**

Airports are displayed with aerodrome symbols together with their name, which can be configured in variety of ways.

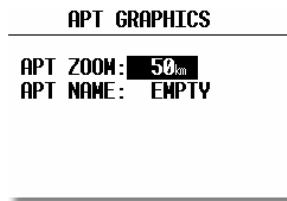

**APT ZOOM:** The airport zoom setting defines the **ZOOM** range under which the airports will be displayed. For instance, a 50 km setting will only show the airports when the selected **ZOOM** range is 50 km or lower; at greater **ZOOM** ranges, the airports will not be shown. The permitted settings are: ON, OFF, 5, 10, 20, 50 and 100 km.

**APT NAME:** The airports are displayed by an airport symbol with the adjacent name or designator as selected below:

- **ICAO** will show ICAO code of the airport adjacent to the symbol
- **2 char, 3 char, 4 char, 8 char** will display the first 2, 3, 4 or 8 characters respectively of the airport name.
- **NONE**, displays only the symbol with no code or name

**2.3.3.8.4 TP (Graphics)**

The same logic is used for displaying turn points except that some further choices are available.

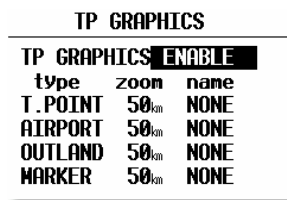

There are four types of turn points, and each type is designated by a different symbol on the screen (see para 3.2.2).

- **T. POINT** This is simply a turn point at which it is not possible to land
- **AIRPORT** This is an airport used as a turn point
- **OUTLAND** This is a turn point at which an outlanding is possible
- **MARKER** This is used to designate a temporary point, such as a good thermal source. It is deleted when the instrument is switched off (See also para 2.4.4)

**Note!**

If a turn point is designated as **OUTLAND**, then it will also be displayed in the **NEAR AIRPORT** screen with the corresponding symbol. (See para 3.2.2)

**2.3.3.9 PILOTS (Pilot list)**

The LX 7007 PRO IGC has the capability of storing up to 30 pilots names, each with their **specific configuration** preferences. The list is active as soon as the first pilot has been entered under **FLIGHT INFO** and copied into the pilot list. (see para 3.1.1.2 and para 2.3.1.2)

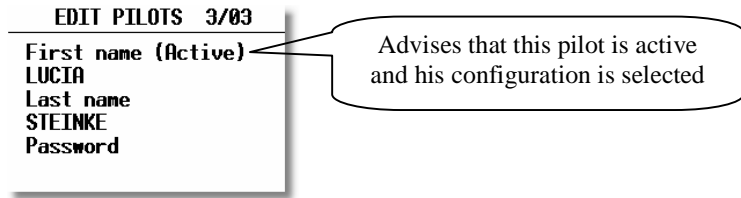

Each pilot has the capability, if needed, of **protecting** his configuration by means of a **personal password**. Password input is possible after activation of **EDIT** function. This ensures that a particular pilot's configuration can not be selected and **altered** by another pilot. Without using of password the pilot specific preference settings will match the last settings flown by this pilot, if nobody else has used his name and have made some changes.

New pilots can be added (INSERT) and existing pilots edited simply by pressing **ENTER** in the following screen:



**Note!**  
Pilot selection from this menu is not possible. Switch the unit OFF and ON and select another pilot.

The second way to input a new pilot is transfer of **Flight info** from LXe or Colibri/LX20 or to **Upload flight declaration** from ConnectLX. **SD Card** transfer of Flight info is also possible. After successful transfer open **LOGGER/FLIGHT INFO** and confirm **ADD PILOT TO LIST** wit Y.

**Note!**  
If the same pilot is flying for instance 15m and 18m variant of the same glider it is recommended to enter two slightly different names, to be able to store two different sets of settings. For instance Peter15 and Peter18.

Logger	INIT	Display
--------	------	---------

**Pilot proper preference data, SEUP Level 1 (Setup)**

TP	WARNINGS	GPS	UNITS	GRAPHIC	NMEA
PC PORT	USER PORT	POLAR	LOAD	TE COMP.	INPUT
LCD IND	PAGE 1	PAGE 3	AUDIO	VOICE MOD.	ALARMS
FLARM	INTERFACE	*****	*****	*****	*****

**Pilot proper preference data, SEUP Level 2 (System Setup)**



### 2.3.3.10 NMEA/PDA (NMEA output for PDA)

The LX 7007 PRO IGC is capable of outputting position data sentences in the NMEA format for use by other devices. The various output configurations are shown below and by placing the cursor on any one and pressing **ENTER**, the individual NMEA sentences will be displayed. If See You Mobile, Navigator or Winpilot is used, then **PDA** should be selected in this option. Selection **DISABLED** will make computing of **LX 7007 faster**, so it is recommended to **disable** the output, if not used.



**Note!**

The NMEA baud rate will be always **19200** bps, doesn't matter any other settings. The data is **exclusively** available on PDA interface connector.

**Note!**

**LX Mobile** PDA program users will receive data about active **task** (LXTSK sentences) **automatically**. They have to use PDA setting. PDA is factory set.

After enter on any item a table of enabled NMEA sentences will be shown for a short time. An exception is EXPERTS where the pilot has an opportunity to enable sentences of his interest. Select only sentences which are **necessary for your PDA** operation, to many enabled sentences will load LX 7007 microcontroller without any reason. It is recommended that the pilots who **don't use PDA** disable all NMEA sentences.

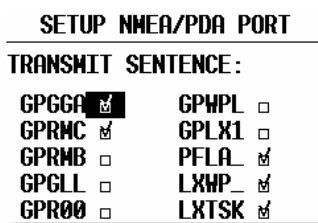

NMEA sentence	Information sent	Necessary for PDA operation
GPGGA	Position, time.....	Y
GGRMC	Position time....	Y
GPRMB	Includes information about destination	N
GPGLL	See NMEA standard	N
GPG00	See NMEA standard	N
GPWPL	See NMEA standard	N
GPLX1	Data for SeeYou Mobile and Winpilot	N
PFLA_	Flarm data	Pilot decision
LXWP_	Data for SeeYou Mobile and Winpilot	Y
LXTSK	Info about selected task on 7007	Y

**Note!**

**PFLA\_** data sentences which include **Flarm data** for PDA are also available on PDA port. Use PDA (automatically included) or EXPERTS to enable mentioned sentences.

### 2.3.3.11 USER PORT

This is a completely autonomous RS 232 port, which may be used as a NMEA output at 4800, 9600, 19200 or 34800 bps.

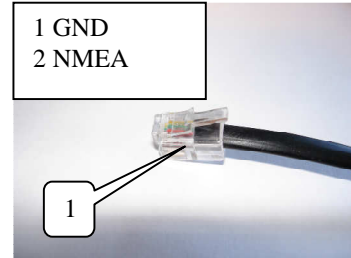

There is also 12V DC power output on the connector pin 4.

### 2.3.3.12 DEL TP/TSK

This option allows all programmed turn points and tasks to be globally deleted. If **Y** (Yes) is selected, then all turn points and tasks will be deleted and can not be retrieved. **Be careful with this option.**

### 2.3.3.13 POLAR

Polars for most gliders are in the library. They are selected by simply rotating the **UP/DOWN** selector.

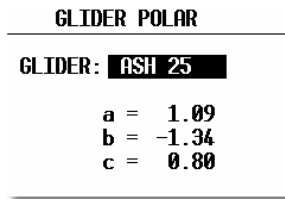

The polars are defined as a quadratic notation with the parameters a, b, and c. If a suitable polar is not found in the library, or it is required to define a **USER** polar, then the program POLAR.EXE, which is contained on the CD accompanying every instrument, should be executed. The program requires that 3 points on the new polar are entered at selected speeds (eg. 100 km/h, 130 km/h, and 150 km/h). The program will then calculate the values of a, b and c which should be noted and entered into one of the two **USER** polars (rotate **UP/DOWN** anti-clockwise). Finally, the name 'USER' should be replaced with a selected polar name as it subsequently appears as the glider type in the IGC recorder file.

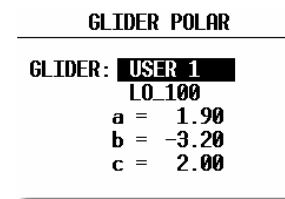

### 2.3.3.14 LOAD

Each time the instrument is powered up, the ballast settings are set to the minimum. By setting the **SWITCH ON LOAD: SET**, the ballast setting will remain at the last setting made on the previous flight and will not be zeroed on instrument power up.

After selection of **kg or lbs** in menu **Units**, a very simple manipulation on the field and also during the flight will follow. The pilot input of ballast is now in kg or lbs. To make this possible some additionally inputs should be done as follows:

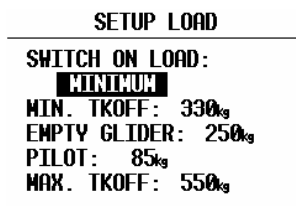

MIN.TKOFF : default glider plus minimum pilot weight (see glider operational manual)  
 EMPTY GLIDER : empty glider weight (see manual)  
 PILOT : pilot weight  
 MAX.TKOFF : maximal take off weight

### 2.3.3.15 TE COMP. (Total energy compensation)

The LX 7007 PRO IGC offers two methods of vario TE compensation.

- TE tube
- Electronic TE compensation

#### Note!

It is important to note that the method of TE compensation is set up when the instrument is installed by the pneumatic Connections made to the TE and Static ports. Changing the compensation type in the setup screen below **WILL NOT** change the method of compensation - the pneumatic plumbing has to be changed first (see Chapter 5 - Installation).

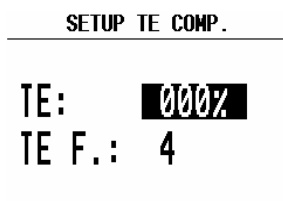

**If the TE tube option has been installed, then TE: should be set to 0%**

There is no further adjustment of the TE is possible; the quality of the TE tube is the only factor.

**If the Electronic TE option has been installed, then TE: should be set to 100%**

The TE compensation can be fine tuned during flight with the following procedure. It is essential that this is only done in smooth air; it is not possible to tune the TE accurately when it is thermic.

- Select 100 % and default TEF
- Accelerate up to approximately 160 km/h (75 kts) and keep the speed stable for a few seconds
- Gently reduce the speed to 80 km/h (45 kts)

Observe the vario indicator during the manoeuvre. At 160 km/h the vario will indicate about  $-2$  m/s (-4kts). During the speed reduction the vario should move towards zero and should never exceed zero (slightly positive indications are acceptable). If the vario shows a climb, then the compensation is too low, increase the TE%; and vice versa. Try another zoomie to assess the change and make further adjustments if necessary.

The **TEF** (TE filter) is the compensation delay. Larger numbers will increase the delay and vice versa. During the first test is recommended to use TEF 4.

Electronic TE is only effective when the pitot and static sources are co-located and the pneumatic lines to the instrument are approximately the same length. The best sensor to use is the combined pitot/static Prandtl tube. If problems are experienced with the electronic TE compensation, then the most likely cause is the glider's static source. The static source can be checked by plumbing the pneumatic tubes for electronic compensation and then setting the **TE:** to 0%. In still air, accelerate to approximately 160 km/h and slowly reduce the speed. Observe the vario indicator. If the static source is good, then the vario should immediately start to move to show a climb. If the needle firstly shows increased sink and then moves to a climb, the static source of the glider is unsuitable and there is no way to provide successful TE compensation electronically. The use of a dedicated and accurate fin mounted pitot/static source such as a Prandtl tube might help.

**2.3.3.16 INPUT (external SC switch)**

The LX 7007 PRO IGC has an input for an external speed command switch, which is **wired to LX 7007 AU**. Using the external switch it is possible to switch between SC and Vario manually. Setting the **SC INPUT** to **ON** means that closing the switch will cause the instrument to enter SC mode, and setting **SC INPUT** to **OFF** means that closing the switch will select Vario mode. There is a third option by setting SC INPUT to **TASTER** and Connecting a push button to the input, each key press will toggle between SC and Vario (obligatory setting after using of LX Remote).

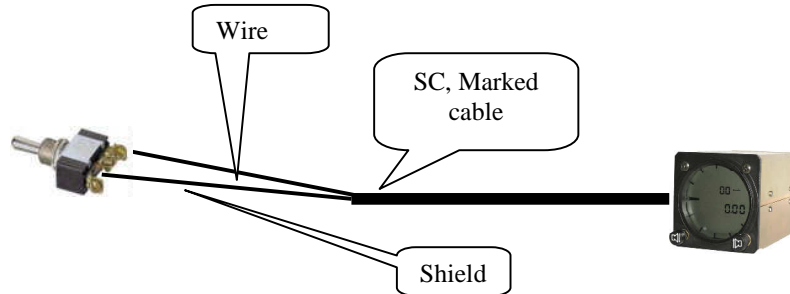

Wire	Shield	Open	Setting: ON	Staus: VAR
Wire	Shield	Closed	Setting: OFF	Staus: SC
Wire	Shield	Closed	Setting: ON	Staus: SC
Wire	Shield	Open	Setting: OFF	Staus: VAR

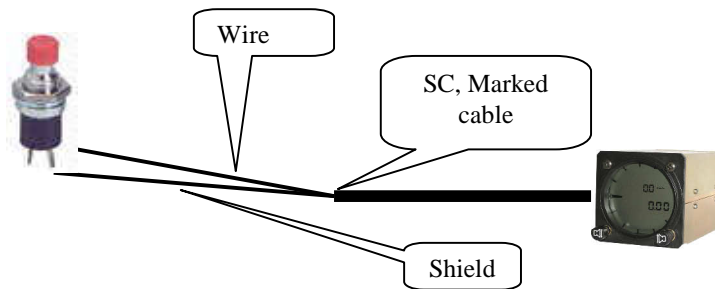

A voice message “Stalling” will be generated if, IAS will go below the value specified in STALL W: xx km/h. Acceptable IAS input is between 60 and 120 km/h. Mentioned function is active exclusively, if LX Voice Module option is used.

The LX 7007 PRO IGC is supplied with an external temperature sensor. Selecting **TEMP. ON** will enable temperature measurement by the sensor. Setting **TEMP. OFF** permits the user to **offset** the temperature reading.

**Note!**

There is another input called **VARIO PRIORITY**. When this input is activated by grounding the appropriate wire, the unit will change over to Vario immediately. This input wire is set open (not grounded) as a factory default on delivery.

**2.3.3.17 LCD IND. (LCD – Vario Indicator)**

The LCD vario indicator is a part of LX 7007 AU. Unlimited number of secondary vario indicators can be also Connected to the system using the 485 system bus. The LX 7007 PRO IGC provides 4 different sets of data that can be displayed on the vario indicators. This means that up to **4 indicators can be set to display different information**; any further Connected indicators are simple repeaters. Each LCD indicator is set up from the following menu:

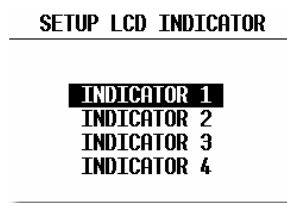

An LCD vario indicator consists of:

- Needle
- Two numerical displays (upper and lower)
- Labels and indicators

These following functions can be set (see next picture):

- Needle Vario needle (Vario, SC, Netto or Relative)
- SC Ring Displays speed command at all times
- Upper Numeric Display Upper line, the parameter displayed can be configured in both Vario and SC modes
- Vario Mode Indicator Shows current flight mode (vario or speed command)
- Lower Numeric Display Lower line, the parameter displayed can be configured in both Vario and SC modes

The labels will automatically be displayed depending on the current function. The **BAT** warning will be displayed when the supply voltage is below 11 volts.

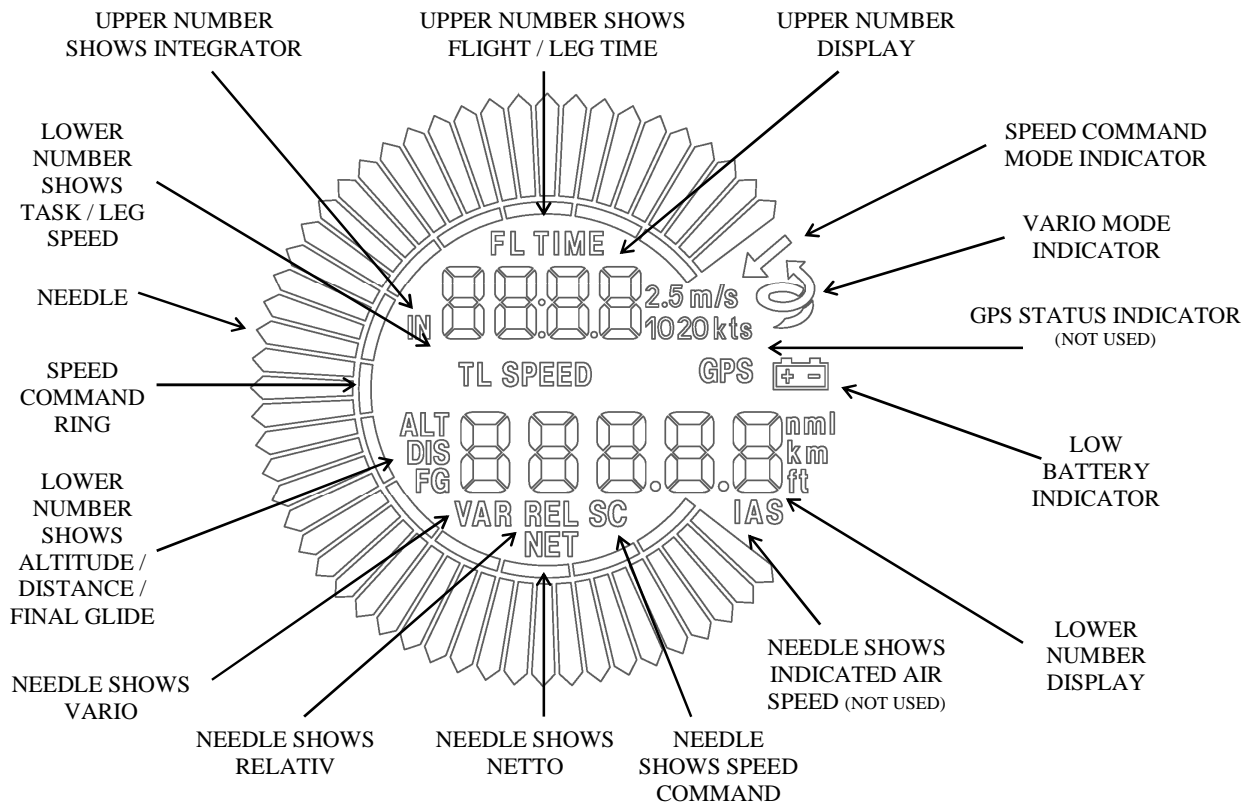

**Note!**  
The vario indicator built into the LX 7007 AU is always **Indicator 1** (no settings possible).

Each further indicator (available as an option) has a **DIP switch on the rear side** that sets and identifies the indicator and enables it to be programmed under that identification. The positions of the switches are listed below.

SW 1 ON	Indicator set1
SW 2 ON	Indicator set2
SW 3 ON	Indicator set3
All OFF	Indicator set4

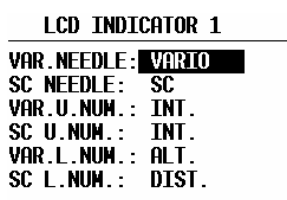

After identification, the needle and the two numerical displays of each indicator can be programmed to display the following parameters:

All settings should be made for vario and speed command mode separately (e.g.: VAR NEEDLE =needle in vario mode, SC NEEDLE = needle in SC mode).

#### Needle settings:

- Vario, SC, NETTO or RELATIVE (= netto – 0.7 m/s),

#### Upper numerical line:

- Integrator, time, flight time, leg time

#### Lower numerical line:

- **ALT.** (NN altitude), **DIST.** (distance to the navigation point), **GL. DIF.** (final glide altitude difference), **SPEED** (TAS), **LEG SP.** (speed on leg), **QNH(ft)** (NN altitude in ft), **F.LEVEL** (flight level). The last two items requests version 1.16 or higher of LX 7007 AU.

### 2.3.3.18 COMPASS

This unit is an optional extra. The compass module is connected by the 485 bus to the LX 7007 PRO IGC. If the compass is connected, this setting enables the compass to be calibrated and this is described in Chapter 7. If a compass module is not connected, the COMPASS setting is not active.

### 2.3.3.19 ENGINE (Engine Noise Level)

This page shows the current ENL reading to confirm that it is operating correctly. **No adjustment** is possible.

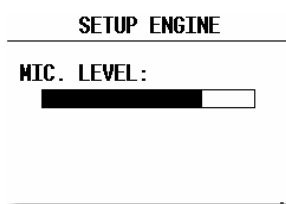

#### Note!

A proper ENL operation will show min.  $\frac{3}{4}$  of bar during engine active time)

2.3.3.20 PAGE 1 (Main Navigation Page)

There is a choice of three variants of the layout of this page. The three pages are shown below; the third variant being the default:

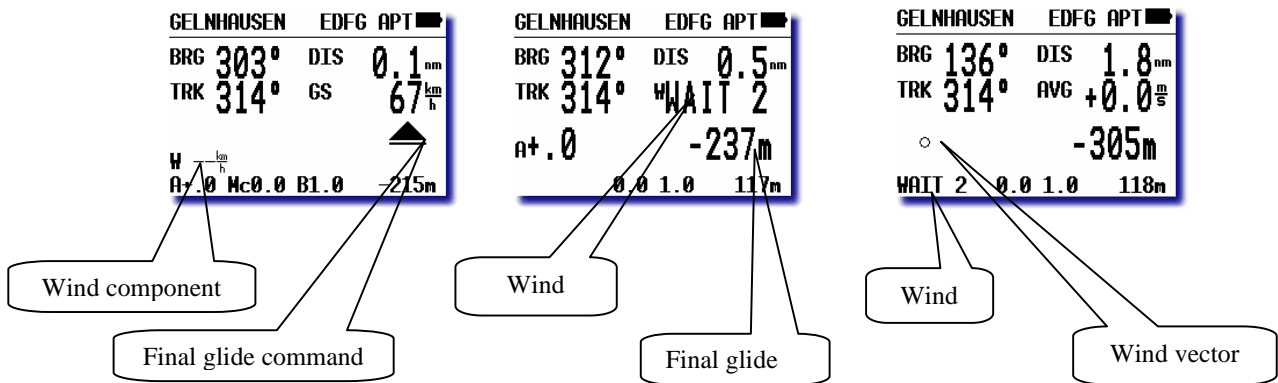

Variant 3 will bring useable information in SC, actual glide ratio and the minimum glide ratio to reach the point.

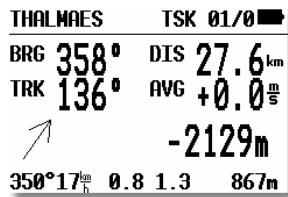

Vario

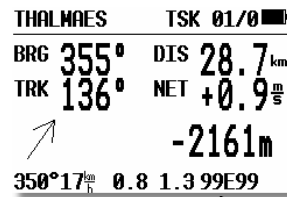

SC

Actual and min glide ratio to reach finish, TP or APT

2.3.3.21 PAGE 3 (Additional Navigation Page)

This page can only be activated or disabled. Default set is OFF.

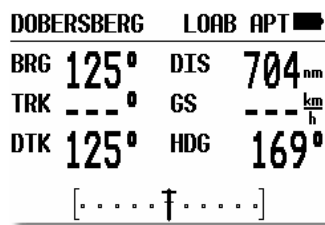

### 2.3.3.22 AUDIO (Adjustment of audio )

A wide variety of audio variants can be configured by user:

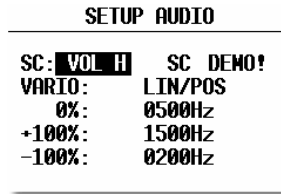

- SC: VOL H audio volume will be increased by speed command (H) or decrease by ( L)
- VARIO: Several types of audio can be selected (use DEMO to hear the choices available)
- 0% Tone frequency at 0 m/s
- +100% Tone frequency at full + deflection
- -100% Tone frequency at full – deflection

### 2.3.3.23 ALARMS

The unit produces an audio alarm on reaching certain confirmation points. This screen allows the parameters of the audio to be configured.

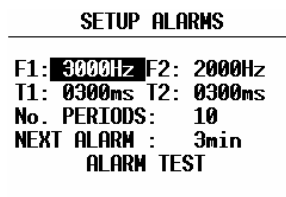

**Note!**  
If a Voice Module option is used, the alarms will be **disabled** automatically.

### 2.3.3.24 FLARM

Only units equipped with Flarm option will open this menu.  
Here are four sub pages of Flarm menu.





2.3.3.24.1 SETTINGS

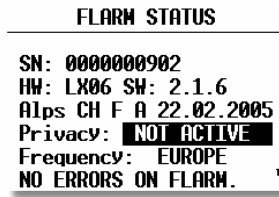

HW, SW version and obstacle data base status can be read. There are no inputs in this menu, an exception is the Frequency and Privacy input. Frequency must correspond to the region of operation. **Privacy active** means that the glider using this option will transmit reduced amount of data, only the data absolute necessary to prevent collision will be sent. Suggested setting is **NOT ACTIVE**.

2.3.3.24.2 TRAFFIC INFO (Flarm traffic information display)

A short press on EVENT button in any navigation mode will open a traffic information display. To define screen orientation use this menu as follows:

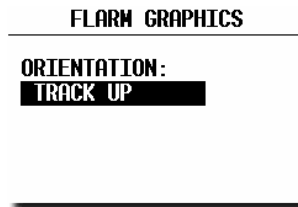

- NORTH UP** : always **north up**
- CIRC.NORTH UP** : **north up** during circling period, during straight flight an automatic change over to **track up**
- TRACK UP** : always **track up**

2.3.3.24.3 TURN OFF (TURN ON)

The pilot has a possibility to switch Flarm in his glider any time off. After switched off, an identical procedure should be run to switch Flarm again on. After ENTER a very clear message will inform about the action.



2.3.3.24.4 TIME LOCK (Flarm)

Under some conditions (competitions) it is not allowed to receive extended data (vario, ID...) via Flarm. After using of TIME LOCK input only collision avoidance relevant data will be received for a pre-entered period of time. After expire the whole Flarm functionality will be available again.



**Note!**  
There is no way to unlock the unit before expire

**2.3.3.25 SD CARD (SD card formatting)**

Every SD card which is intended to communicate with LX 7007 should pass **initialisation procedure**. This menu does this job. The cards delivered with the LX 7007 are already formatted. If a **new card** will be used it is compulsory to run **formatting procedure**.



ENTER

**Note!**  
FAT 32 formatted SD cards will no be accepted by the system. Use FAT 16 formatted cards, delivery included card is already formatted and ready for operation

**2.3.3.26 INTERFACES (Otions)**

Options listed above may be connected to LX 7007 system bus. Every active option should be **checked** in this menu.

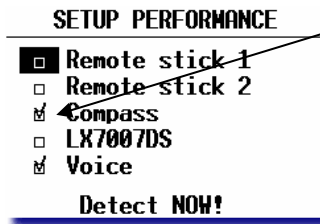

**Note!**  
Not checked items will be not accepted by LX 7007 and will also **not operate**, even connected to the bus. A very typical message **DISABLED** will appear in **HW Check** procedure during booting. If an option is not present on the BUS a message **Not Detected** will describe this situation. A **Ready** message shows Option ready for operation.

Activation of **Detect NOW** will show actual status and will automatically **enable** (☑) all in the moment present units.

**2.3.3.27 PASSWORD**

There are several passwords which runs some specific procedures listed below:

PASSWORD	ACTION
01049	“Auto zero” will set vario to and speed to zero
55556	Enables Condor simulator input via PC port
55557	Enables Condor simulator input via IGC port
99999	Will permanently delete all flights from the flight recorder

**2.3.3.28 INFO**

After ENTER on Info detailed data about firmware will be present.

## 2.4 Navigation Functions

The LX 7007 PRO IGC has the following navigation functions displayed on six main pages. The pages are selected in sequence by rotating the **MODE** (↔) selector:

- **GPS** - Status and Coordinates
- **NEAR AIRPORT**
- **APT**, - Airport
- **TP** - Turn points
- **TSK** - Tasks
- **STATISTICS** - These can be accessed both during flight and after flight using the **LOGBOOK** function

### 2.4.1 GPS Page

This page is purely informative; no configuration is possible.

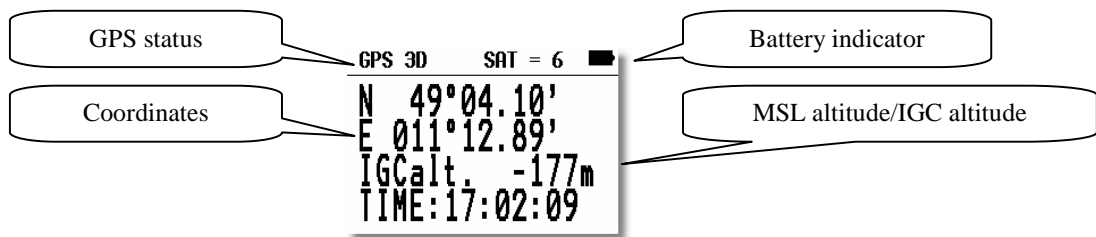

By rotating the **UP/DOWN** selector the displayed altitude will appear in both m and ft at the same time and at the end IGC altitude will be shown..

The **TIME** display can be changed to a Stop watch as follows:

- Press **START** status **STOP: 0:00**
- Press **START** status **RUN: 0:12**
- Press **START** status **STOP: 0:50**
- Press **START** status **STOP: 0:00 Reset**
- Press **ENTER** and **TIME: 11:56:32** is re-activated

### 2.4.2 NEAR AIRPORT

This option displays the nearest airports, both from the APT database and the TP list, together with those turn points that have been selected as being land able. The airports are sorted by distance with the closest first. Simply place the cursor with the **UP/DOWN** selector on the desired airport and press **ENTER**. The LX 7007 PRO IGC will change to APT mode and all navigational features will be available.

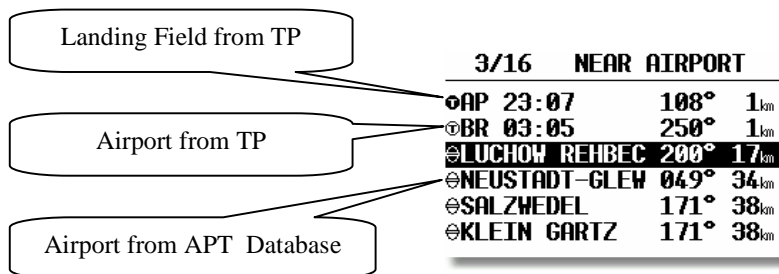

**Note!**

The symbol preceding the name indicates which database the landing point has come from. See the examples above.

**Voice!**

After selection the distance and runway data of selected airport will be expressed.

### 2.4.3 APT Airports, TP Turn Points and TSK Tasks

The three main navigation modes (APT, TP, TSK) are selected by rotating the **MODE** selector. All three options are similar and have similar basic navigation data screens accessed by turning the **UP/DOWN** selector. The first page shows the basic navigation data (bearing, distance, ground track and ground speed). The airport memory of LX 7007 PRO IGC has a capacity for approximately 5000 airports. The airport data can not be edited in the instrument; all necessary updates should be done using a PC. The database used in LX 7007 PRO IGC is a **free database**. The database can be downloaded from the Internet using the following addresses:

[www.lxnavigation.si](http://www.lxnavigation.si)

#### 2.4.3.1 Navigation in APT, TP or TSK

There are five navigation pages; the first one is described below.

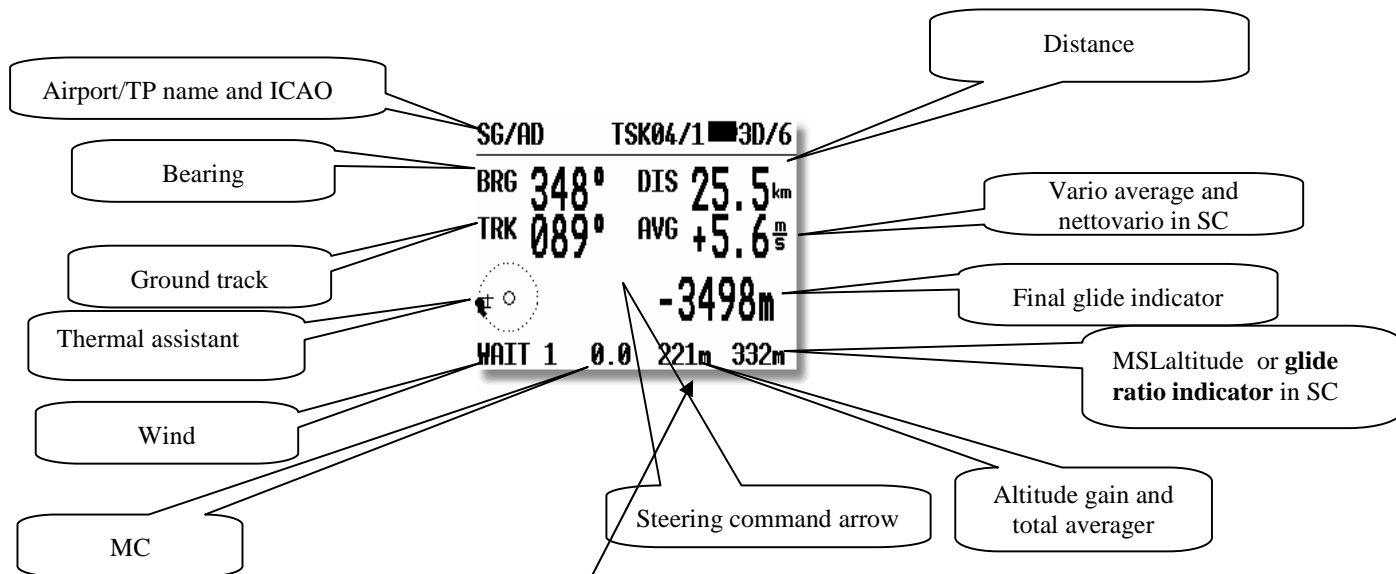

**Note!**  
 The glide ratio indicator consists of two numbers separated with an E (43E77) and is active exclusively in SC mode.. The left figures show the average glide ratio achieved during the last two minutes, while the right figures show the minimum glide ratio required to reach the APT, TP or finish the task. The over-range indication is '99', which means that the glide ratio is in excess of 99:1. When **flying a task**, the minimum glide ratio is calculated on the total distance to the finish line, including all uncompleted TPs, and any pressed safety altitude. This function is very useful when the final glide is being set up around one or more TPs

**Note!**  
 During circling period the **Altitude gain** will be indicated in the lower right corner of the display. The detection of circling is done automatically and couldn't be influenced by pilot. The indicator shows how many **meters or feet** has been gained or lost during the actual circling period.  
 As the glider detects straight away flight, the indicator will change in to so called **Total Averager**. This figure shows the last thermal real average climbing, it is division of gained altitude and the time spent in the thermal..

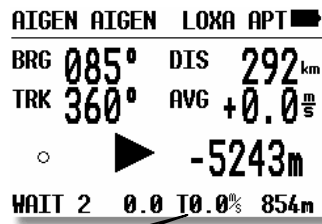

Total average

The Airport and TP names are normally displayed using 8 characters, but by pressing the **START** button, 12 characters of an airport name will be displayed for few seconds. The course correction arrow (Direction Indicator) shows which way to turn (left or right) to reach the desired APT or TP.

Rotating the **UP/DOWN** selector will bring up the graphic page. The airports will be shown with symbol and short names or ICAO-code. (see para 3.1.2)

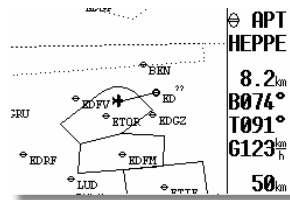

Ground speed

The glider symbol remains in the centre of the screen and the map moves under it. To adapt the displayed range, simply rotate the **ZOOM** knob anti-clockwise to increase the range or clockwise to decrease it.

In all three navigation modes (APT,TP or TSK) the graphic page offers also steering information and **Off Track** distance. Steering info consists of an **arrow symbol** and a **numerical figure**. The arrow may be oriented left or right and the orientation depends on direction to which the pilot should steer to come back to the course. The number informs about off course in degrees, it shows difference of actual track and bearing.

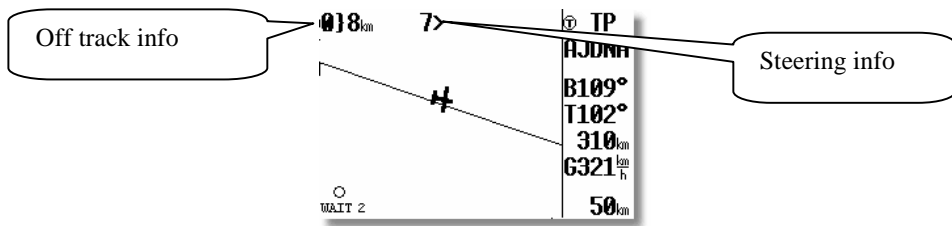

Off track info

Steering info

The **third** navigation page includes a course deviation indicator (CDI). This page is default disabled and can be at any time enabled in setup under the **PAGE 3** option.

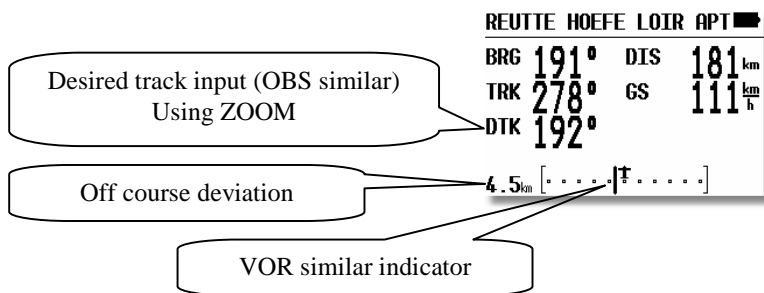

Desired track input (OBS similar) Using ZOOM

Off course deviation

VOR similar indicator

Further rotation of the **UP/DOWN** selector will call up the fourth, or arrival page.

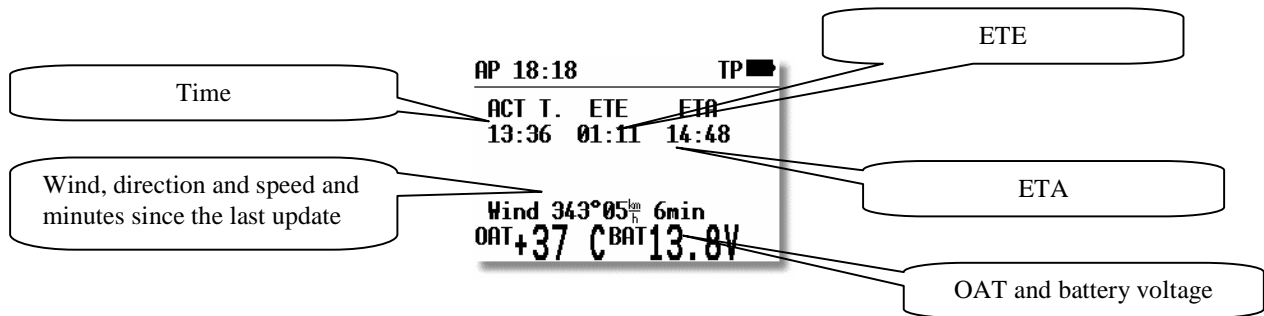

**ETA** (estimated time of arrival) and **ETE** (estimated time enroute) define the arrival time and the time needed to reach the destination. Both depend on the settings in the INIT menu. Default setting is VAR, means vario average during the flight, MC or GS can be preset and this setting will be valid until power off, a new one will set VAR again. If the glider is not tracking in the direction of the selected point (track and bearing differ more than 90°), both times will be replaced with stars. The age of the last **wind update** in minutes is displayed after the wind vector.

Note!  
This page is in TSK menu extended with some task relevant data, See also 2.4.5.2.

Continued rotation of the **UP/DOWN** selector will show the last page, where details of the selected airport will be displayed.

```

NEUSTADT-GLE EDAN APT
ELEV.: 35m
RWY: 09/27 G
TC: ----m I
TOWER: 123.37MHz
    
```

The data is self explanatory except for the traffic circuit, **TC** details. The pattern height together with its orientation (N or S) is displayed. The letter **I** means that the pattern details are not defined.

### 2.4.3.2 Airport Selection, Team and Wind Calculation

After placing the cursor on the function required and pressing **ENTER**, a menu appears which offers airport selection, the team function, or selection of the method of wind calculation.

```

MENU APT
-----
SELECT
TEAM
WIND
    
```

### 2.4.3.2.1 SELECT - Airport Selection

There are two ways to select an airport. If the ICAO locator is known, it can be directly entered when the name of the airport will be displayed.

```
APT SELECT
-----
ICAO: EDDM
      GERMANY
MUNICH
```

If an incorrect letter is entered, then either press **START** or rotate the **ZOOM** selector to move the cursor back so that the letter can be re-entered.

If the ICAO locator is unknown, then the following method should be used. With the cursor on **ICAO**, press **ESC** to move the cursor to the country. Select the required country with the **UP/DOWN** selector and press **ENTER**. Four stars will now be displayed at the airport name. Using the **UP/DOWN** selector and **ENTER**, input the first four letters of the airport name. All airports with the same first four letters will be available and can be cycled through by use of the **UP/DOWN**.

If you input less than four characters, the number of airports that fit the first x letters will be greater. If all four stars are confirmed with **ENTER** or after pressing **ESC**, all airports of the selected state are available and can be cycled through in alphabetical order.

```
APT SELECT
-----
ICAO: EDBM
      GERMANY
APT: M****
```

#### Note!

Rotating of **ZOOM** will select airports directly. This feature is active only from the upper navigation page.

#### Voice!

After selection the distance to the airport will be expressed.

**2.4.3.2.2 TEAM function**

This special function has been developed to help pilots flying in a team to locate each other if they loose visual contact. Both pilots have to select the same destination point (APT, TP or TSK). One pilot then passes his range and bearing to the selected point by radio. The second pilot then selects TEAM FUNCTION and enters the range and bearing passed by the first pilot.

**Example:**

If 347° and 24.1 km is the range and bearing given by the first pilot. After entering the figures and pressing ESC, the instrument will change to the normal **TP navigation page** and the data will show the position of the first pilot.

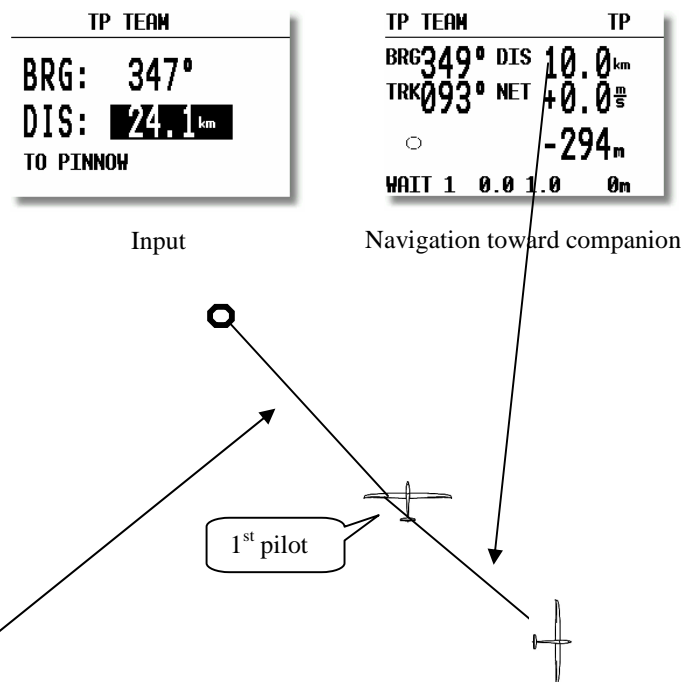

**Example:**

If 347° and 24.1 km is the range and bearing given by the first pilot. After entering the figures and pressing ESC, the instrument will change to the normal **TP navigation page** and the data will show the position of the first pilot. The team function is deactivated **after a new APT or TP** is selected.

**2.4.3.2.3 WIND calculation method selection**

The LX 7007 PRO IGC is able to calculate the wind vector. This function is the same in all three navigation modes. A further method, COMPASS, is available only after an optional compass unit is Connected to the LX 7007 PRO IGC RS485-bus. To change the method of wind calculation, use the following menu:

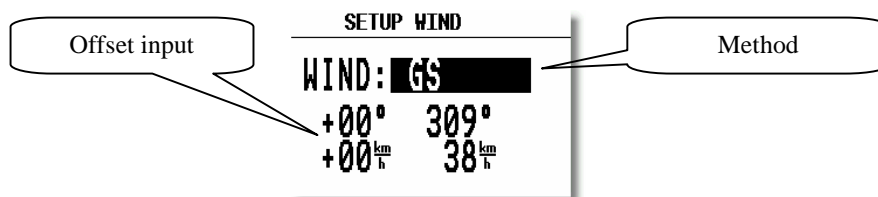



**GSPEED DIF.** is the simplest method. The calculation is based on measuring ground speed changes while **circling**. A minimum of two full circles are necessary to obtain an accurate wind. The message **WAIT2** or **WAIT 1** informs the pilot how many circles are left to get the result. It is very important **to keep the speed constant** while circling to ensure that accurate results are obtained. The pilot is able to adjust the wind using manual corrections through the Offset Input.

**POS. DRIFT** is the most accurate method. It is based on measuring the drift due to the wind during 6 full circles. These circles have to be flown accurately and at a constant speed to achieve the best results. **WAIT 6 to 1** indicates how many circles are left until a result is produced.

**COMBINATION** is using a combination of two methods:

-during the climbing a very reliable method GSPPED DIF. is used and during straight flight an algorithm which calculates wind after input of GS,GTand TAS. The change over between methods is done automatically.

**COMPONENT** calculates the **wind component** (head or tail wind). The calculation is based on measuring the difference between GS and TAS during straight flight.

**FIXED VALUE** is not a calculation; it simply allows the pilot to input the wind vector that he wants to use.

**COMPASS** wind calculation method is available only with the optional compass device. Its use is described in the COMPASS manual.

Note!

The results of wind calculation are present in the left lower corner of the first navigation page as an **arrow symbol** and as numeric **information**. The arrow is track up oriented. The same is present in graphic page also; in this case a **north up** orientation should be respected.

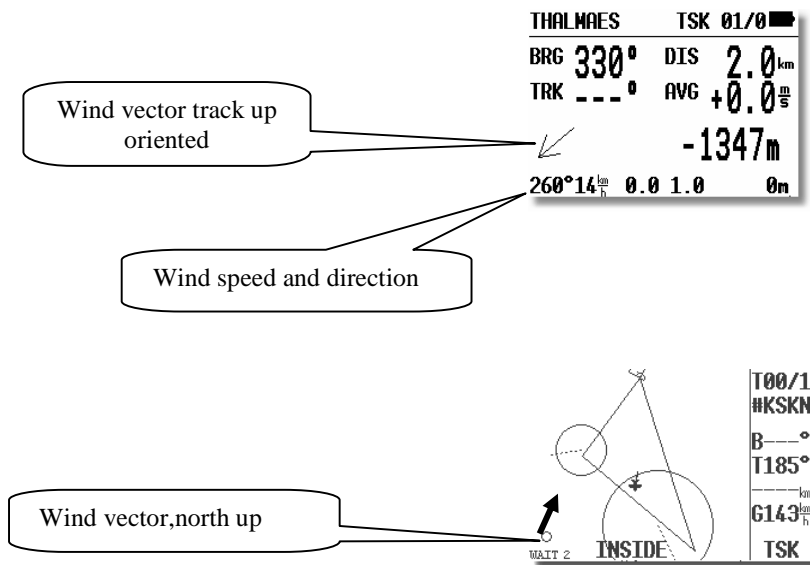

### 2.4.4 TP - Turn Points

The LX 7007 PRO IGC has the memory capacity to store up to **600 turn points**. The turn point name can have a maximum of 8 characters (letters or numbers, **no lower** case letters and no **special signs** except \* and \_). The menu structure is the same as in the APT menu - either four or five pages depending on the set up parameters. A turn point can be added to the database in one of five ways:

- Manual input
- Copy from APT database

- Data transfer from a PC, PDA, LX20 or Colibri (\*.DA4 format)
- Read from SD card (.da4 only)
- Input of actual position (Marker)

**Note!**

Using of **ConnectMe/ConnectLx** PDA programs, makes possible to transfer turn points in **.cup** (See You turn point format) format directly into LX 7007. The conversion .cup-.da4 will be done automatically. Transfer of LX original **.da4** format is also possible.

The procedure is similar to the method of selecting an **APT**. While in any **TP** page, press **ENTER** and a menu showing **SELECT, EDIT, NEW, DELETE, TEAM** and **WIND** will be presented.

**2.4.4.1 TP SELECT**

To select a turn point simply replaces the stars with the first letters of the TP.

**Note!**

LX 7007 is able to sort turnpoints by **alphabet** or by **distance**. Default setting is sorting by alphabet (2.3.2.3). Result of selection by distance is (all stars confirmed) selection of nearest TP. Using of **↕** will offer next more distant TPs.

**Note!**

It is also possible to select TP by using **ZOOM** selector. This works exclusively from **the first page**. To change the TP simply rotate the **ZOOM** selector. This method will work also, if sorting by distance will be active.

**Voice!**

After selection the distance will be expressed.

### 2.4.4.2 TP EDIT

This option allows the pilot to change TP data at any time. The turn points used in LX 7007 PRO IGC can have four attributes. Using attributes, when the turn points are displayed in graphic pages, they will be represented by different symbols. The four different types of turn points are as follows:

- **T.POINT** normal TP, not landable
- **AIRFIELD** landable airfield
- **OUTLAND** landable outlanding place
- **MARKER** temporary marker which will be deleted when the instrument is switched OFF

Ts having an **airport or outland attribute are landable** and are shown on the NEAR AIRPORT page. In front of the name the pilot will see a symbol indicating what kind of landing place it is (see NEAR).

To start **EDIT** press **ENTER**.

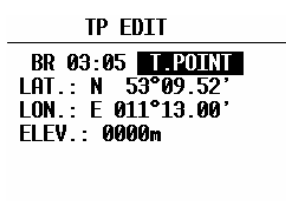

Name, attribute, coordinates and elevation can be changed at any time.

Note1  
Turnpoints as result of storing position have default attribute MARKER.

### 2.4.4.3 TP NEW

Place cursor on **NEW** and press **ENTER**. The following window will be displayed.



'Y' allows a new turn point to be copied from the **APT** database. If it is required to enter a completely new turn point, then select 'N'. A second menu will then be displayed allowing the name, co-ordinates, attributes and elevation of the new turn point to be entered.

### 2.4.4.4 TP delete

If this option is selected, then delete confirmation will be requested. If the reply is 'Y', then the turn point will be deleted and can not be recovered.

### 2.4.4.5 TEAM

This function is the same as described under APT in para 3.2.3.2.2

### 2.4.4.6 WIND

This function is the same as described under APT in para 3.2.3.2.3

### 2.4.4.7 Storing of Actual Position

The procedure can be exclusive activated by pressing the **START** button while in **TP- main page only!** A message

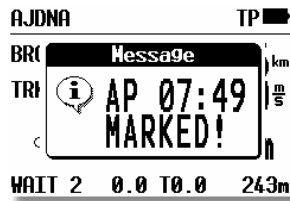

will be present for a short time.

This means that a TP having name AP 07:49 with **Marker** attribute has been stored. Edit or select of such a point is at any time possible.

### 2.4.5 TSK - Task

The LX 7007 PRO IGC can store up to 100 tasks, with each task containing a maximum of 10 turn points (start , 8 turn points and finish). Selecting and storing a task offers the following benefits:

- Accurate task statistics
- Simpler navigation
- Automatic change over to next TP after confirmation
- TSK shown on the graphic display
- One further step of **ZOOM** (full task)
- Full AAT support (Assigned Area Task)

**Note!**

The final glide calculation in TSK mode is calculated from the **actual position** to the finish point, via all uncompleted turn points. Final glide to a single turn point or airport is available in the TP or APT modes.

The menu structure is similar to the APT and TP. Graphic data about the start, TP confirmation zone and finish line is particularly useful.

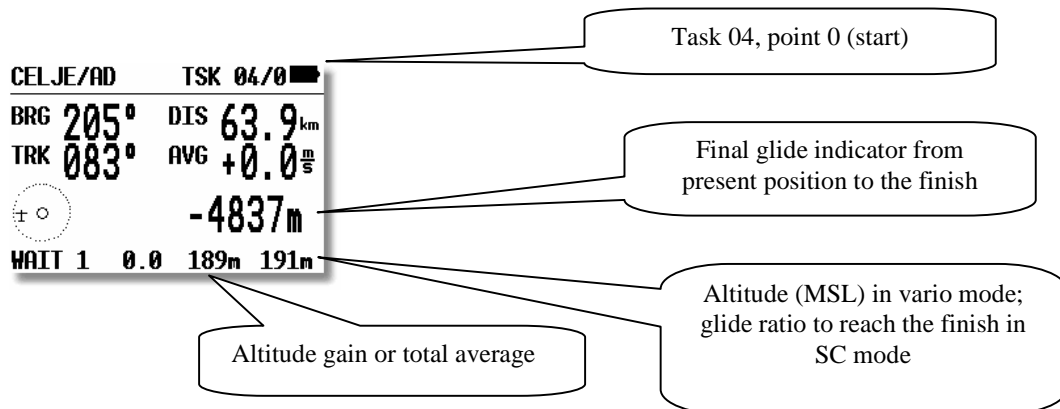

When approaching a TP, a **NEAR** message is displayed to inform the pilot that he is closing on the turn point. When the glider enters the observation zone, then the message **INSIDE** is displayed.

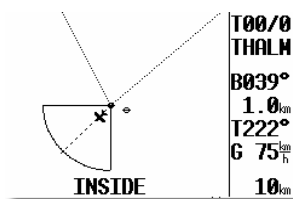

The tasks are numbered from 00 to 99 and the turn points building a task numbered from 0 to 9. Point 0 is always the start point.

### 2.4.5.1 TSK - SELECT

All stored tasks can be viewed by choosing **SELECT** and pressing **ENTER**. All pre-programmed tasks can now viewed by rotating the **UP/DOWN** selector; once the required task is displayed, it is selected with **ENTER**.

**Note!**

Using the **ZOOM** knob is possible to select tasks by simply **rotating** the knob. This function is active only from the **main navigation page**. After each selection, the total task distance is shown for a short time to help to decide which task to choose. The total task distance displayed is the sum of the length of all the task legs, **plus** any additional distance to reach the start point.

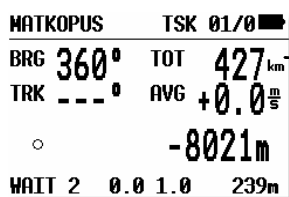

Total distance for apr. 2 sec.

**Note!**

Selection of a new task isn't possible, if a task has been already started. Use RESTART first.

**Voice!**

After selection the total task distance will be expressed. After ESCAPE during flight the distance to go will follow.

2.4.5.2 TSK - EDIT

The active TSK can be edited at any time, doesn't matter on the ground or during flight. An already **over flown** can not be edited.

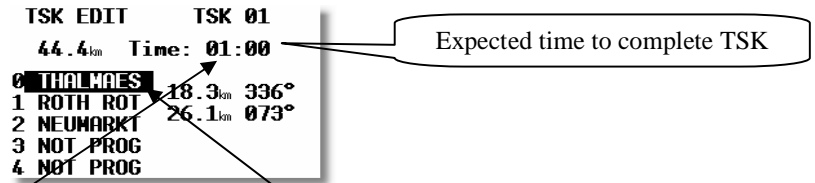

The expected time to complete the task is entered in hours and minutes. While this input is not obligatory, doing so will allow progress to be monitored during an AAT which normally requires to be completed within a specific time window. Once the task is started, this time runs toward zero and the extended ETA/ETE page will show a lot of additional information (see flying LX 7007 pro IGC). **The task time** is possible to be adjusted any time also after the task has been already started. See also capture Fly LX 7007

If a turn point is to be inserted, changed or deleted, the desired turn point is selected with the **UP/DOWN** selector and on pressing **ENTER**, a **sub menu** opens up:



- **SELECT** replaces the selected turn point with another
- **INSERT** adds a turn point above the one selected
- **DELETE** removes that turn point from the task
- **ZONE** and **MOVE** relate to AAT (see below)

Assigned Area Tasks (AAT) - Special Functions

Up to five tasks of the 100 programmable (from 00 to 99) can be designated as AAT. Each individual task point can be configured for an AAT by using **ZONE** and **MOVE**. If **ZONE** and **MOVE** do not appear on the sub menu, then five tasks are already modified for AAT. The AAT modified tasks are active **for three flights only**. After the third flight all sectors are set back to the default settings (as defined in **SETUP/OBS.ZONES**) This feature allows the competition pilot to make three take offs without loosing the AAT information.

- **ZONE-** Using this function, an individual sector can be defined for each turn point of the task. In the following example TP 0, the start sector at Thalmaes is defined

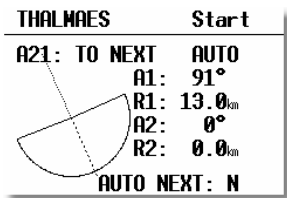

A21, A1, A2, R1 and R2 have the same meaning described in **SETUP/OBS. ZONES** (See capture 2.3.2.3)

The final option. **AUTO NEXT** defines what happens after reaching the programmed zone. When flying "normal" speed tasks, with **AUTO NEXT** set to Y (Yes), the LX 7007 PRO IGC will change over to next turn point immediately after a fix is recorded in the sector. In an AAT this is not very useful, because of big sectors and the need to use the **MOVE**

function. Setting the AUTO NEXT to N (No) prevents the LX 7007 PRO IGC from switching to the next turn point when reaching the sector. The pilot must switch over manually by making a short press of the **START** button. In the example below an individual sector with 60° has been set at the first turn point and the automatic switch over disabled.

**Example:**  
Selecting R1 more than 6 km, will set **AUTO N** automatically.

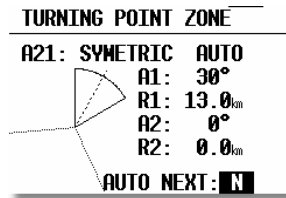

Start is default N, the TP will automatically change to N after **MOVE** function is activated.

**Note!**  
Editing a task and the corresponding sectors can also be done during flight. (See 'Flying with the LX 7007 PRO IGC')  
See capture 2.4.5.2.

- **MOVE** In an AAT the sectors are generally quite large; therefore it is reasonable to consider modifying the task during flight. All AAT's (max. 5, see above) offer this possibility. Moving of the turn points is allowed inside the sector only.

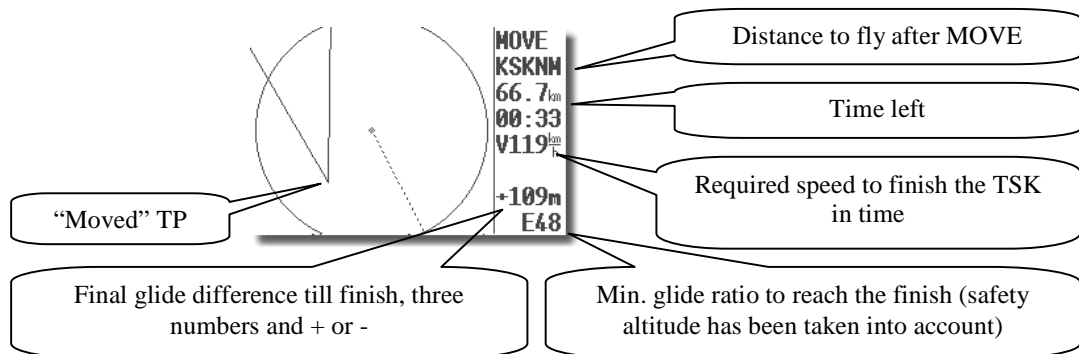

Having used MOVE-function,, the "new" point acquires a '#' as the first character of the name (very significant). The sector and the reference point stay unchanged, but all navigation data is modified corresponding to the new (virtual) point. For example, the final glide is now calculated around the new point, and the statistics are modified in the same way.

The point will move after using the rotary knobs **UP/DOWN** and **ZOOM**. The up down knob will move the turn point **radial** and zoom will **rotate** the turn point. It is not possible to **MOVE** outside the sector. Use up down knob at first and than zoom. Unless a specified task time (task edit) has been entered, the required speed and remaining time to complete the task will **not be displayed**.

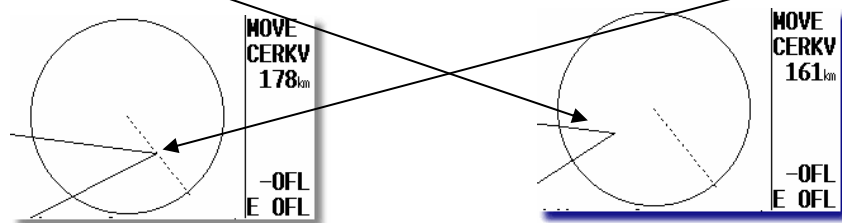

### The extended arrival page

Using of this page will give the pilot extremely important information about arrival, flying a task. Especially after using of MOVE function during AAT.

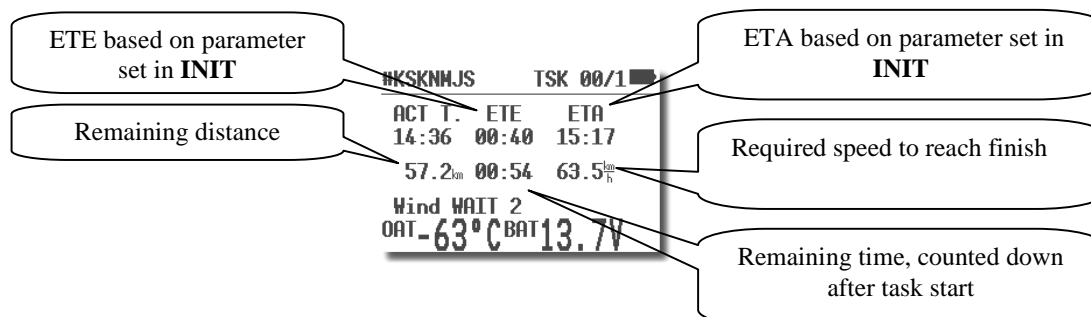

The **remaining distance** is the distance from actual position to the finish line. If the task has not yet been started, then this distance includes the distance to reach start also.

The **remaining time** is the time left to finish the task, simple count down after task start (active only after input TIME in TSK edit).

The **required average speed** is calculated from remaining distance and the remaining time.

**Note!**

ETA and ETE are calculated using the parameters defined in **INIT** under ETA (GS,MC,VAR). Default setting is VAR, means daily vario average.  
By pressing **ESC**, the ETA and ETE calculated to the actual TP are displayed for 3 seconds.

### 2.4.5.3 TSK - NEW

Pressing **ENTER** with the cursor on **NEW** will select a sub menu asking whether an existing task should be copied. If N is selected, then the next available task with all points un-programmed will be selected. Sometimes it is easier to copy an existing task and then amend it; pressing 'Y' allows this to be done.

### 2.4.5.4 TSK - DECLARE

For all FAI flights (badges, records, and decentralized competitions) the task should be declared before take off. This procedure replaces the requirement to make a **written or photographic declaration**.

**Note!**

The declaration will not change the instrument functions. The declaration is only the procedure to show that the flight was planned before take off. All manipulation and functions of the LX 7007 PRO IGC will be the same whether the task is declared or not. The only difference is in flight validation is that the declaration is recorded in the .IGC file.  
**Redeclaration during flight is not possible.** Editing the task during the flight, or fly another task will **not change the declaration**.

Pressing **ENTER** with the cursor on **DECLARE** will display the following sub menu:

TSK DECLARE			
Dist.: 163.5km			
0	THALMAES	TAKE OFF	
1	THALMAES	63.1km	041°
2	094SULZB	23.8km	106°
3	087SCHMT	76.6km	238°
4	THALMAES		



All known methods (select, insert, and delete) can be used to change the declaration at this stage. **Changing of declaration will not change the TSK.** The take off and start points as well as finish and landing points will usually be the same. If these points are not identical in your task you have to change either start point or take off point as necessary.

**The normal procedure for declaration is:**

- Prepare **TSK** in **TSK/EDIT** menu (you will need it for navigation later).
- Press **ENTER** on **DECLARE**, check it is correct and then press **ESC** to make the declaration.
- A short **message** on the screen will then show the time and date of the declaration

**Note!**

If the task declaration procedure has not been made before take off and a believable task has been flown, then an afterward declaration will be written into IGC file, such a declaration is **not valid for official IGC flights (time of declaration after landing)**, but can be used for pilot private flight evaluation. Only declarations made before the flight (manually or via flight info data transfer) will fulfil IGC requirements.

**Important!**

The declaration is **valid for one flight**. After each landing a new “declare” procedure should follow. If the unit has been switched off, without providing any flight, the declaration **will remain**.

**Voice!**

Task is declared.

#### 2.4.5.4.1 Declaration using of LXe, Colibri/LX20 or PDA

LXe: use **write Flight Info** data transfer

Colibri/LX 20: use **Read Flight Info**

PDA: use ConnectLX/ConnectMe or SeeYou mobile

**Note!**

For more details about declaration see chapter 3.1.4.2. A declaration transfer has no influence on any task stored in LX 7007, all tasks will all remain unchanged. The change of task data base is only possible after .da4 file transfer..

#### 2.4.5.4.2 Declaration after using of SC card

All necessary declaration data can be also transferred via SD card after transfer of “Info” file having extension .hdr. Such a file can be created with LXe after using of Flight Information option.

### 2.4.6 START OPTIONS

This menu makes possible to input start Altitude and Ground speed limit, if this parameters are limited according to competition regulation. See para 3.3.1 for details.

### 2.4.7 STATISTICS

There are two levels of statistics; flight statistics and task statistics. Flight statistics becomes active immediately after take off and task statistics is activated once a start is made. (see Para 3.4.4.7) On ground Logg book is shown in this page.

#### 2.4.7.1 Statistics during flight

##### 2.4.7.1.1 Flight statistics

The following page is exclusively visible during the flight and for a few minutes after landing, before the instrument switches to 'Calculating Security' procedure.

**STATISTICS**

**FLIGHT:**  
 1:07:12 - 1:14:51  
**Duration:** 0:07:38  
**Vario:** ---% 0%

**2.4.7.1.2 TSK Statistics**

The following statistics is available after the task has been started. Rotation of the UP/DOWN selector permits scrolling through individual legs.

**STATISTICS**

**TSK 00/1: NEUMARKT**

**Time:** ---:--:--  
**Duration:** 0:07:27  
**Speed:** 133<sup>km</sup>/<sub>h</sub>  
**Vario:** ---% 0%

During leg

**STATISTICS**

**TSK 00/1: NEUMARKT**

**Time:** 1:20:15  
**Duration:** 0:12:21  
**Speed:** 146<sup>km</sup>/<sub>h</sub>  
**Vario:** ---% 0%

Completed leg

During an active task leg, the time will remain blank as it is the **TP confirmation time** and is never shown until the TP is confirmed. The completed leg display shows time turn made, the time spent completing the leg (**duration**), average speed on leg and % of time spent climbing. The last shown screen always shows the **task statistics** from the start to the current position.

**2.4.7.2 Statistics after flight**

**2.4.7.2.1 LOGBOOK**

These statistics are available **after flight**. The logbook shows the flights by date with take off and landing time. The logbook entry will appear approximately 3 minutes after landing and is the signal that the flight is finished and that the unit can be switched off.

LOGBOOK		
10.02.02	7:36	7:47
10.02.02	6:24	7:31
10.02.02	4:30	5:53
10.02.02	3:02	3:12
10.02.02	2:37	2:59
10.02.02	2:22	2:31

**2.4.7.2.2 Statistics after flight**

The LX 7007 PRO IGC provides post flight statistics and analysis. To start the procedure, select the flight from the **LOGBOOK** and press **ENTER**.

<b>Flight: 1</b>	<b>30.09.03</b>
<b>PILOT: UNKNOWN</b>	
<b>DURATION: 0:56:28</b>	
<b>14:27:11 - 15:23:39</b>	
<b>Dis.flown: 77.1 km</b>	
<b>Speed: 100<sup>km</sup>/<sub>h</sub></b>	

The flown distance will appear if the unit has any task information (either a programmed TSK or a simple task - see para 3.4.4.7). If no task information is available, then the **TASK NOT SPECIFIED** message will appear. Speed is average speed on task.

After pressing **ENTER** the pilot is able to recall the route flown and the barogram.

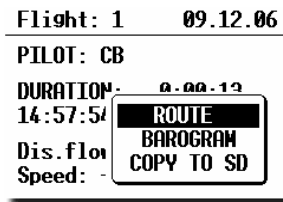

- **ROUTE** - route flown will be shown

On pressing **ENTER** with the cursor on **ROUTE**, the display shows:

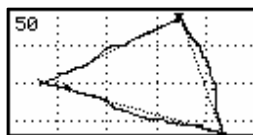

after ZOOM

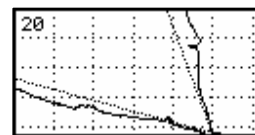

To program ZOOM, press **ENTER** and a small cross will appear in the middle of the screen. Move the cross by rotating ZOOM and the UP/DOWN selector. Press **ENTER** when the cross is positioned at the start of the area to be zoomed. Repeat the procedure for a second cross and place at the end of the area to be zoomed. Press **ENTER** and the expanded area will be displayed.

- **BAROGRAM** - barogram of the flight

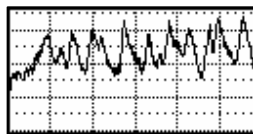

after zoom

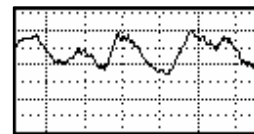

The zoom procedure is similar, but there is no cross. After pressing **ENTER**, a vertical bar will appear which can be moved (with **UP/DOWN**) and fixed with **ENTER** again. The same procedure is used to place the second bar.

- **COPY TO SD**

After Enter the flight will be copied to SD card. The procedure will take some seconds. Both LX original format .LXN and IGC compatible file .IGC will be stored automatically.

Note!

If the card has been inserted for a longer time the contacts may get not conductive and a message "Can't find SD Card" may appear. In this case pull the card out and insert again.

## 2.5 Variometer and Altimeter

All signals from the pneumatic sensors (altitude, speed) are derived from high quality pressure sensors which means that no flask is necessary. The vario signal is derived from the altitude signal. All signals are temperature and altitude compensated. A custom programmable LCD has been designed to display the vario information as well as many other parameters. The display is user configurable.

The variometer can be configured to show:

- range                      5,10 and 2.5 m/s    10,20 and 5 kts
- five time constants    1s to 5s, in addition there are 4 settings of electronic processing for the vario signal
- netto vario              air mass lift and sink
- relative vario            shows the lift or sink that would be achieved if the glider was circled at thermalling speed

There are two ways by which the vario indications can be corrected for total energy; electronic TE compensation based on speed changes with time; and pneumatic compensation with a TE probe. When using pneumatic compensation after using of TE probe, the LX 7007 BASIC **does not process the signal at all**. The quality of the TE compensation depends entirely on the location, size and dimension of the TE tube. The installation must be leak-proof.

**Note!**

If electronic TE compensation is selected, then the TE(Pst) port should be connected to a good static pressure source. If pneumatic compensation is selected, then the TE(Pst) port should be connected to the TE probe.

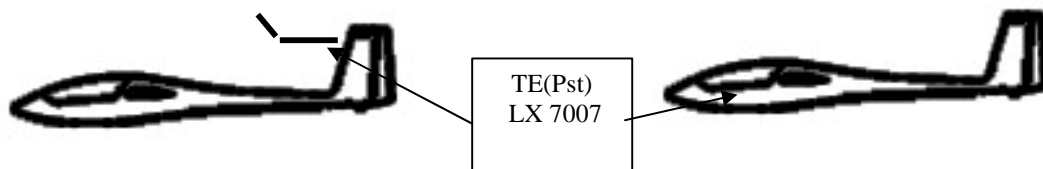

Compensation with TE probe

Electronic compensation

### 2.5.1 Smart Vario description

The LX system incorporates two configurable electronic filters in the circuitry. The first filter adjusts the time constant and is adjustable between 0.5 and 5 seconds. The 0.5 setting is the fastest while the 5 setting provides maximum damping.

The second filter, called the Smart Vario, is a dynamic filter and controls the rate at which the vario indication moves. When set to OFF, there is no restriction on the rate of movement of the vario indication other than the setting of the time constant filter. When set to 1, the vario indication will not move faster than 1 m/s (2 kts) per second, while when set to 4, the vario indication will not move faster than 4 m/s (8kts) per second. It should be noted that when set to 4, the vario indication will move four times faster than when set to 1.

Summary:

- The Smart Vario should not be used in isolation but in conjunction with the setting of the time constant filter. When the Smart Vario is activated, the time constant filter may need further adjustment to provide optimum indications.

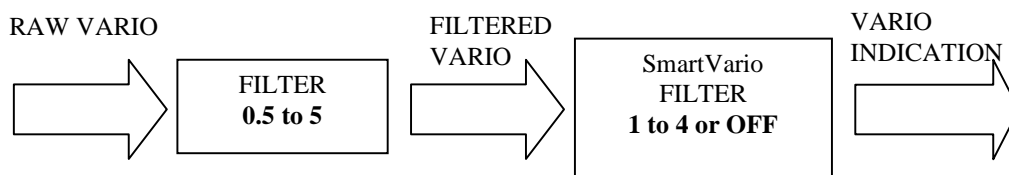

## 2.5.2 Altimeter

The altimeter of LX 7007 PRO IGC is temperature compensated from -20°C up to + 60°C. The altimeter is calibrated from 0 to 6000m (20,000ft), but indication goes up to 8000m (26,000ft).

Important!

After correct **field elevation input** the altimeter indication will always be MSL (Mean sea Level).

### 2.5.2.1 IGC barogram recalibration procedure

LX 7007 PRO IGC has an **additional pressure sensor** for altitude recording. To comply with IGC procedures, this sensor has no external pneumatic Connection. To carry out the baro calibration procedure it is necessary to remove the instrument from the glider and place it in a vacuum chamber. The procedure is as follows:

- Switch the instrument **ON**, and wait some minutes (straight line on the barogram beginning)
- Set logtime to 1 second
- Place it in the chamber and carry out a short climb to about 100m (to start flight recorder)
- Bring the chamber pressure to exactly 1013.2 hPa
- Decrease the pressure by 1000m and hold for about 30 seconds
- Continue the procedure to 6000m
- Increase the pressure in 1000m steps back to 1013.2 hPa
- After reaching ground wait about 3 minutes and switch the instrument off
- Leave the instrument minimum 5 minutes off
- Download the last flight and print the barogram using the Lxe PC program
- Restore flight recorder settings

The barogram will be the last flight in the logbook.

## 2.5.3 Speed command

Speed command flying based on the McReady theory is a very useful tool to optimise cross country speed. There are many visual indicators (see LCD Vario). When the instrument changes to speed command mode, the audio will change and become a director informing the pilot whether he is flying too fast or too slow. In order to reduce confusion between vario and speed command audio, some special features were developed:

- Continuous audio signal in + possible (other kinds of signals can be chosen, see setup)
- No audio at correct speed (dead band).

## 2.5.4 Final glide calculation

The final glide calculator calculates the **final glide altitude difference** to the selected point (APT, TP). In the task mode the final glide is always calculated from the current position, round all uncompleted turn points to the goal. A + indication will inform the pilot that the glider is above the final glide slope and vice versa. The final glide takes into account **Mc setting, wind, bugs and safety altitude**.

**Note!**

The elevation of the finish point is imported from the TP database into the final glide altitude difference. If this elevation is incorrect, or is set to zero, and the altimeter is set to QNH, then the final glide will be in error.

**It is therefore important that the elevation of the goal is correctly entered in the TP database.**

The safety altitude (reserve) input does not affect the glide difference indication which should be 0 m/ft during the final glide. It simply means that the glider will arrive over the goal at the selected safety altitude.

## 3 Flying with the LX 7007 PRO IGC

To get the best out of the LX7007 PRO IGC, it is important that some preparation is done prior to the flight – trying to configure the instrument or set up a task while flying the glider may spoil your whole day! Pre-flight preparation will ensure that the flight will be both successful and enjoyable.

### 3.1 Flight preparation on ground

Pressing the **ON/START** button will switch on the LX 7007 PRO IGC. The instrument will go through the initialisation phase and stop on the pilot selection. On selecting the pilots name and pressing enter it will continue the initialisation until the **Set Elevation** menu (entering elevation of the take off airfield) is reached. If the instrument has not previously been programmed, the pilot name selected will be 'UNKNOWN' and it will go straight to the **Set Elevation** page, the same will happen, if there is no pilots stored in the pilot list, means a single pilot solution is used.

**Note!**

It is **recommended** to switch the unit ON **some minutes before take off**, to give time to the GPS receiver to **acquire** enough satellites and that the flight recorder will build a **base line**. Longer time ON, will not reduce flight recorder capacity due to **circular logging** during stop status.

#### 3.1.1 Single pilot option

If only one person fly's the glider, then only his name should be programmed into the instrument through **FLIGHT INFO**. The LX 7007 PRO IGC will then show the name of the pilot during the initialisation procedure and switch automatically to the **Set Elevation** page. Don't confirm SAVE TO PILOT LIST with Y.

#### 3.1.2 Multipilot option

Up to 30 pilots can be stored into the pilot list of the LX 7007 pro IGC. The first pilot has to be entered into the **FLIGHT INFO** and then copied into the pilot list via **ADD PILOT TO LIST (Y)**, this command will be activated automatically after leaving of Flight info (ESC). Further pilots can be registered under **SETUP / PILOTS** with **INSERT**, or via **PC/PDA** data transfer at any time. Pilots, who want to have their individual settings **safe**, should use **EDIT** (under **SETUP / PILOTS**) and input a **personal password**. After password input only persons who will know the password will be able to use protected name and settings.

**Note!**

Individual settings done by pilots will be automatically stored and will be recalled after mentioned pilots name will be selected after power on. To keep individual data safe, the pilot is able to prevent his settings by a password, which is available in **SETUP/PILOTS**.

After the initialisation routine, all pilots are selectable using the **UP/DOWN** selector and pressing **ENTER**. If the cursor remains on the **first letter** of the pilot name, it indicates that more than one pilot name is stored and selection becomes **obligatory**. The pilot name 'UNKNOWN' is always available and can be selected.

**Note!**

After selection of UNKNOWN **the last active settings** will be restored.

If the pilot name has been sent via PC or PDA (usually after declaration transfer) or input by hand and **not saved** (**ADD PILOT TO LIST N**) to the pilot list, such a pilot will be treated like a **temporary** pilot and his data will be lost after a **new selection**, but will remain after power off. Temporary pilot will overtake the **last active settings**.

Glider: <b>ANT.18ST</b> Pilot: <b>UROS KRASOVI</b>
---

**In Summary:**

- If **UNKNOWN** pilot name is selected, then the **settings** from the last flight, irrespective of the pilot, will be used.
  - If a **Pilot** without a password is selected, then the settings of the last flight **by that** pilot will be used.
  - If a **Pilot** with a password is selected, another pilot is not able to use his name or alter any of his stored settings.
- A **temporary** pilot (not included in the pilot list) will be offered, if transferred by PC or manual input until first new selection. After first selection will be deleted permanently.

**Note!**

If a single pilot flies the glider in different configurations, then it is recommended that he uses the multi pilot option listing his names as 'AN OTHER 15m' and 'AN OTHER 18m' for instance. This will ensure that the correct polar will be used as it is one of the stored individual settings.

**Voice!**  
**Set pilot.**

**3.1.3 SET Elevation (take off elevation input)**

We all know that air pressure changes all the time and it is important that the altimeter is re-referenced before each flight. After completing the initialisation, the instrument requires that the elevation of the present position is entered.

Set elevation: <b>0037 m</b>
---------------------------------

**Voice!**  
**Set elevation.**

This setting is **obligatory**. The instrument will offer the last airport which was on the top of the NEAR AIRPORT list. If this is OK, the pilot can either simply confirm the offered elevation, or alter it. After setting the elevation, an input of the current QNH setting is called for. This is not mandatory, but very useful as by entering the QNH will enable the pilot to subsequently alter it as necessary during the final glide. If the QNH is not entered, it can be ignored by pressing **ESC**, but the pilot will then be unable to subsequently alter the QNH setting during the final glide.

Set elevation: <b>0037 m</b> Set QNH: <b>1010mb</b>
--

**Setting QNH**

- Rotate **UP/DOWN** and 1013 mb will be offered
- Use **ENTER** and **UP/DOWN** to enter actual value

**Note!**

The unit will offer the elevation of the airfield which was on the top list in NEAR, just before regular power down.

**Note!**

If the QNH is not set in the start up procedure, it can not subsequently be changed in flight.

**Voice!**  
(Set QNH)**3.1.4 Preflight check**

It is strongly recommended to check all settings of following items:

- QNH/RES
- INIT
- Ballast if not defined with **set** in setup LOAD

**3.1.5 Preparing a task**

While it is advisable to prepare the task correctly before taking off and thus avoid mistakes made in haste, all the following actions, with the exception of a FAI Declaration, can also be done during flight.

**a) Entering the task**

- Transfer the task file (.da4) from a PC,PDA (transfer of .cup also possible), LX20 or Colibri
- Read .da4 from SD card
- Copy a similar one and edit it (saving of time)
- Enter a new task manually.

**b) Check task**

- **Right TP's**, sequence ,distances between points , bearings and total distance
- **Check visually** task geometry after using of zoom TSK

**3.1.5.1 AAT (assigned area task)**

Assigned Area Task is in fact a speed task where the task distance isn't predefined. The pilot has limited influence on task geometry due to **bigger sectors** which are regularly set. The pilot decides how deep he will fly into individual sector to reach optimal average task speed. Usually **minimum time** spend on task is also set, to prevent flying to short tasks.

**3.1.5.1.1 How to prepare an AAT?**

The AAT has the same structure as whichever other task and all known methods to enter are the same as described. The only exceptions are bigger sectors having **specific geometry**. To prepare sectors use **ZONE menu** for each sector individually.



As described in 2.4.5.2 enter the sector:

- Orientation
- R1 and R2
- Angles A1 and A2
- Check and eventually set AUTO : Y/N (automatic change over criteria)



Note!

Setting **R1 bigger than 10km** will set AUTO: N, means change over to next TP of an AAT will follow exclusively on pilot demand.

To be able to exploit all benefits of LX 7007 AAT functionality it is strongly recommended to input the **time** which is **expected to complete** the task.

TSK EDIT	TSK 01
44.4 <sub>km</sub>	Time: 01:00
0 THALMAES	18.3 <sub>km</sub> 336°
1 ROTH ROT	26.1 <sub>km</sub> 073°
2 NEUMARKT	
3 NOT PROG	
4 NOT PROG	

Expected time to complete TSK

The input depends on **TSK distance**, **weather situation** and **pilot personal prediction**. After successful input the third task page will become complete and will show expected speed over the whole task. The speed is simple division of time and the distance.

CELJE/AD	TSK 00/0	
ACT T.	ETE	ETA
18:28	93:56	16:25
543.1 <sub>km</sub>	05:50	93.1 <sub>km/h</sub>
Wind WAIT 2		
OAT-85	CBAT	13.5V

TSK time

Expected TSK speed

Note!

**Minimum task time** is usually set, by task setter. So, never input **shorter time** than declared in the task sheet. It is suggested to input min. 10 minutes more to avoid premature finish line crossing.

If the expected task speed seems to be not realistic, use **MOVE function** to adapt TSK distance and consequently the speed. MOVE function is available also on ground via edit.

### 3.1.5.1.2 Example of an AAT

The example listed below represents a sophisticated AAT geometry. The most sophisticated is TP 167 which consists of two segments having different radius and are also oriented under task setter requirements.

**Type: Assigned area task with 4 areas**

**Task time: 02:30:00**

**Task distance: 163,5km/344,4km**

Style	Code	Points	Latitude	Longitude	Dis.	Crs.
Take off		000SZEGE	N46,247500°	E020,091383°		
Start		004DOMAS	N46,252500°	E020,026950°		
1.Point		115MELYK	N46,213050°	E019,371383°	50,6km	265°
2.Point		088KISKO	N46,626383°	E019,299450°	46,3km	353°
3.Point		167SZEKU	N46,504167°	E020,542500°	96,0km	98°
4.Point		006SZATY	N46,329450°	E020,053617°	42,2km	243°
Finish		001SZEGE	N46,252783°	E020,090833°	9,0km	161°
Landing		000SZEGE	N46,247500°	E020,091383°		

Observation zone description:

Start 004DOMAS: To Next Point, Line 6,0km

[ Style=To Next Point, A12=Auto, R1=3,0km, A1=45°, R2=0,0km, A2=0°, LineOnly ]

1.Point 115MELYK: Cylinder R=20,0km

[ Style=Symmetrical, A12=Auto, R1=20,0km, A1=180°, R2=0,0km, A2=0°, Assigned area ]

2.Point 088KISKO: R=20,0km, Brg1=150°, Brg2=270°

[ Style=Fixed Value, A12=30,1° R1=20,0km, A1=120°, R2=0,0km, A2=0°, Assigned area ]

3.Point 167SZEKU: Rmin=10,0km, Rmax=20,0km, Brg1=100°, Brg2=180°, Cylinder R=10,0km

[ Style=Fixed Value, A12=320° R1=20,0km, A1=140°, R2=10,0km, A2=180°, Assigned area ]

4.Point 006SZATY: Cylinder R=500m

[ Style=Symmetrical, A12=Auto, R1=0,5km, A1=180°, R2=0,0km, A2=0°, Assigned area ]

Finish 001SZEGE: To Previous Point, Line 1000m

[ Style=To Previous Point, A12=Auto, R1=0,5km, A1=45°, R2=0,0km, A2=0°, LineOnly ]

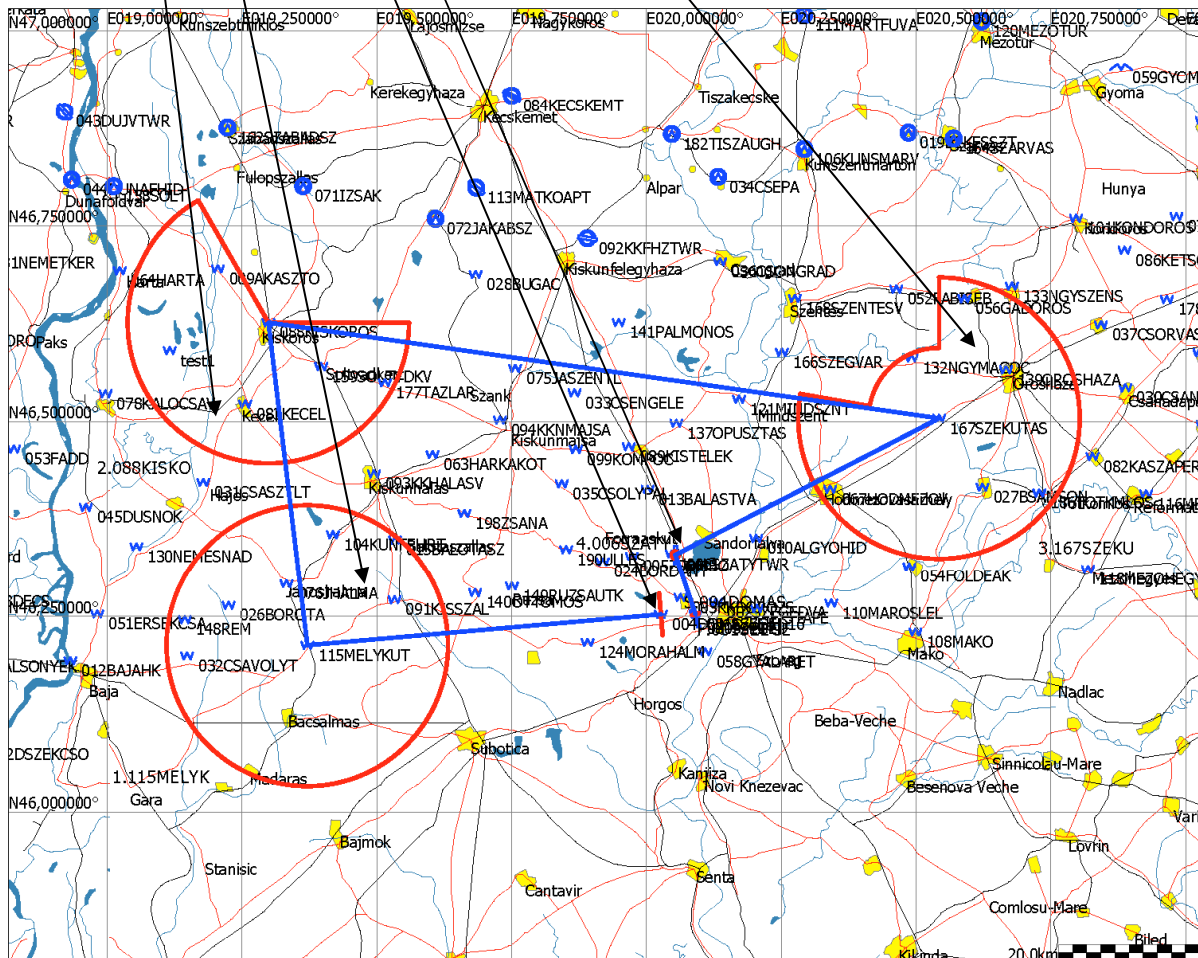

Inputs on LX 7007 regarding above mentioned task sheet.

<b>004DOWAS</b>	<b>Start</b>
A21: <b>TO NEXT</b>	<b>AUTO</b>
	A1: 90°
	R1: 3.0km
	A2: 0°
	R2: 0.0km
<b>AUTO NEXT: Y</b>	



Start: line 2x 3 km

<b>115MELYK</b>	<b>1.Point</b>
A21: <b>SYMMETRIC</b>	<b>AUTO</b>
	A1: 180°
	R1: 20.0km
	A2: 0°
	R2: 0.0km
<b>AUTO NEXT: N</b>	



TP 115MELYKUT: cylinder 20km

<b>088KISKO</b>	<b>2.Point</b>
A21: <b>USER VAL</b>	<b>30°</b>
	A1: 120°
	R1: 20.0km
	A2: 0°
	R2: 0.0km
<b>AUTO NEXT: N</b>	



TP 088KISKO: cylinder cut out having user orientation

<b>167SZEKU</b>	<b>3.Point</b>
A21: <b>USER VAL</b>	<b>320°</b>
	A1: 140°
	R1: 20.1km
	A2: 180°
	R2: 10.0km
<b>AUTO NEXT: N</b>	



TP 167SZEKU: combination of cylinder with cut out and cylinder, having user orientation

<b>006SZATY</b>	<b>4.Point</b>
A21: <b>SYMMETRIC</b>	<b>AUTO</b>
	A1: 180°
	R1: 0.5km
	A2: 0°
	R2: 0.0km
<b>AUTO NEXT: Y</b>	

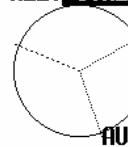

TP 006SZATY: 500 m cylinder

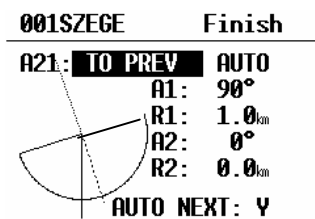

TP 001SZEGE: finish line 2x 1km

Note!

Use task graphic page (**zoom TSK**) to verify, if the task shape corresponds to this given in the task sheet.

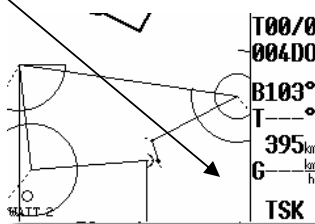

### 3.1.6 Task declaration procedures

The task declaration procedure must be done before take off, if an IGC flight is planned. Declaration or redeclaration during flight is impossible (IGC rules).

### 3.1.7 Manual procedure

This kind of declaration procedure is most common used. It is absolutely necessary to have the task which is intended to be flown (declared) stored in TSK menu and already selected, means **ready for navigation**. Opening of **DECLARE** menu will allow you to **declare the active** task, in a very short time. After press on **DECLARE** all turn points, start, finish, take off and landing will be listed, Use **ESCAPE** to confirm declaration. A very typical message **TASK DECLARE .....** will inform about successful declaration procedure.

Generally the pilot is able to create his declaration without any task programmed using of turn points stored in LX 7007. After using of PC, PDA or Colibri/LX20 a declaration can be transferred which turn points don't match LX 7007 TP database at all. It is possible, but is not very practicable; there will be no task ready for navigation.

Note!

The declaration will be valid for one flight, after landing will be deactivated and a new procedure should follow. If the unit will be switched off on ground the **declaration will remain** for unlimited time.

Voice!

Task is declared.

### 3.1.8 Using of PC

Many PC programs are able to transfer pilot and declaration data directly to LX 7007. Please check functionality before using.

LXe Write Flight info

SeeYou Upload declaration ..... (put a dot after given name to separate it from the name)

All mentioned programs will send **pilot and task data** at the same time. The pilot data will be stored like temporary data and will be deleted after first **new pilot selection**.

**Note!**

It is not rentable to use points which are not included into LX 7007 data base. After having transferred such a declaration, the navigation will not be possible without **adding of missing points**.

We suggest to prepare a **.da4** or **.CUP** file including the task which is intended to be flown, transfer TP and TSK data to LX 7007 and provide **manually declaration**.

**3.1.9 Using of PDA**

Many PDA programs are able to transfer pilot and declaration data directly to LX 7007. Please check functionality before using. Recommended is ConnectLX/ConnectMe, available for free on [www.lxnavigation](http://www.lxnavigation) or [www.naviter.si](http://www.naviter.si). The program is already part of a CD delivered with the unit.

**Note!**

Using of ConnectLX/ConnectMe separate pilots **name and surname** with **dot**. Opposite there will be no separation between name and surname in the LX 7007 flight declaration record. The declaration done via ConnectMe/ConnectLX will not influence TSK stored in LX 7007, means no task prepared for navigation. The pilot should do it manually, or using other programs.

The declaration will be also valid for one flight only.

**Suggestion for SeeYou Mobile users!**

Create the task intended to be flown using of SeeYou Mobile, save the task using **Tools/Save task** command, transfer so modified **.cub** file into LX 7007 by ConnectMe/ConnectLX. Connect program will automatically convert **.cub** into LX format (**.da4**). The new created task will be stored on the first free position. Select task and provide manual declaration procedure on LX 7007.

**3.2 Competition Mode**

To relieve the pilot during competition flight some LX 7007 modes of operation are deactivated, immediately after Competition Mode is **enabled**. In this configuration, LX 7007 offers following modes of operation:

- Turn point
- Task
- Statistics

All other modes are **not available** during Competition Mode active time, of course the Competition Mode can be easily disabled and all LX 7007 modes will be immediately ready.

A **short cut** to Setup will work after a **long press** on MC. This function is active exclusively in Competition mode.

**3.2.1 Competition Mode Enable**

To enable Competition mode is necessary to use SETUP/COMP. MODE menu and select Competition Mode enabled.

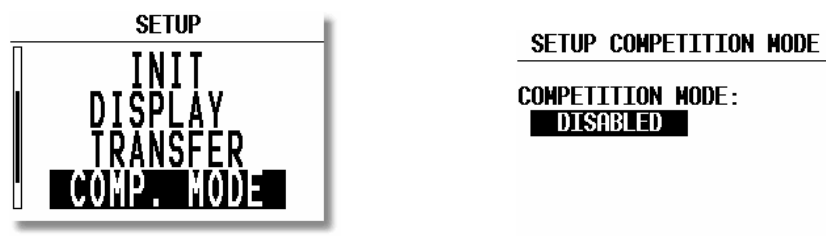
**3.2.2 Competition Mode Disable**

Use long press on MC to activate Setup and disable completion mode..

## 3.3 Performing the flight

After take off, the unit will change over into flying mode. The most significant signal is replacement of **Logbook** with **Statistics** page.

### 3.3.1 Starting a task

The procedure consists of two parts. The first part may happen as the glider has entered the sector and the pilot wants to depart. The second part is executed automatically immediately after leaving the sector (Start line). The procedure:

- Wait until the message **INSIDE** appears on the display accompanied with an audio signal or voice. , This indicates that the glider is in the start sector. Before entering a **NEAR** message will inform about approaching to the sector. This message will be activated as the glider will enter 1 km cylinder. Having big sectors this message may not appear
- Press the **START** button (short press), to arm start.

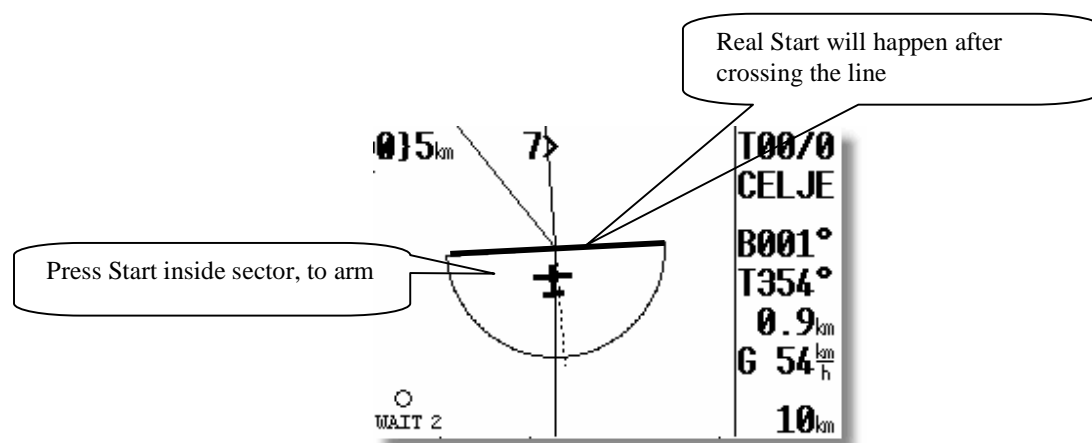

#### Note!

A task can not be started on the ground.

A very clear indication that the start has been armed is change of navigation data. The navigation data will change toward first Turn point. The real start of the task will not happen at this moment. It will happen immediately after the glider will cross the start sector line. This makes start procedure extremely simple, stress less and offers an accurate task statistics, as the statistics will be activated immediately after crossing the start line.

LX 7007 V 1.2 offers a very useful help, if the **altitude and or ground speed** at the line crossing are limited. Both limits are able to be input in TSK Menu/ START OPTIONS.

#### TASK START OPTIONS

MAX. GND. SPEED: 90<sup>km/h</sup>  
MAX. ALTITUDE: 1000m

#### Note!

The altitude input should be in MSL.

A good start will be indicated with an info page which will be removed after 15 seconds and a bad start will be accompanied with a **warning**, but this will remain until pilot confirmation.



Good start



Bad start

It is also possible to start a task, while the glider is **outside the start sector**. In this case the pilot has to press **START** for a **longer time** (about 6 sec), but in any case long enough until the TSK navigation data to the first TP appears.

### 3.3.2 Task Restart

Once the task has been started, it can be terminated (**RESTART**) at any time during flight and a new start made. If a task has already been started, press **ENTER** and the following dialog will appear:



Confirming **RESTART** with **Y** will restore the actual task. The task is now ready for new start. **The restart has no influence on recorded data or declaration.**

**Note!**  
After a task has been started, it is not possible to select a new one. Use **RESTART** and **SELECT** after.

### 3.3.3 Over Turn point (flying a racing task)

By default, the LX 7007 PRO IGC switches over (automatically) to the **next turn point**, as soon as one fix is recorded in the sector of the actual TP. This situation will be accompanied with **INSIDE** message, an audio alarm and voice, if Voice Module is installed.

If a turn point **can not be reached**, the pilot can manually switch (**jump over**) to the next turn point by pressing **START** for **approx. 6 sec.** (just watch navigation data). Alternatively, he can delete the unreachable turn point in the **TASK / EDIT** (recommended procedure). **Neither action has any effect on the declaration!**

### 3.3.4 Switch over flying an AAT

AAT sectors are regularly **big sectors** (LX 7007 2.0 allows inputs up to 999 km) and the pilot has to decide how far into the sector he wants to fly. All sectors having radius **bigger than 6 km** will be recognized as AAT sectors and **AUTO NEXT** will be set to N, means **no automatic change over** to next turnpoint after reaching sector. The change over to next turnpoint should be done manually, by pressing Start.

### 3.3.4.1 Use of MOVE function

Move function helps the pilot to optimize his flight in AAT sector, as he is able to modify the task distance regarding to weather and time conditions. There are two manners of move, an automatic move and move controlled by pilot.

#### 3.3.4.1.1 Automatic move function

Immediately after the glider will enter the sector a move will happen which will modify the task that way, that new turnpoint will be tied to the **momentary glider position**.

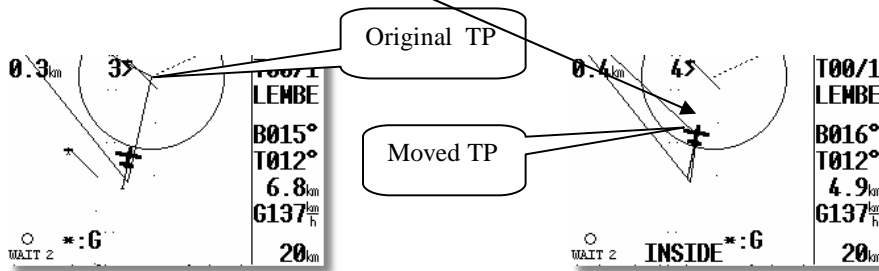

The turnpoint will move continuously with the glider, as long as the glider will remain in the sector. Of course all ETA/ETE data and the distance will 100% correspond to the new situation. To switch over to next TP simple **press Start** button (short press).

CELJE/AD	TSK 00/0
ACT T.	ETE ETA
18:28	93:56 16:25
543.1 km	05:50 93.1 km/h
Hind WAIT 2	
OAT -85	BAT 13.5V

#### 3.3.4.1.2 Manual move

Manual move can be executed at any time even on ground. After a manual move has been used auto move becomes disabled.

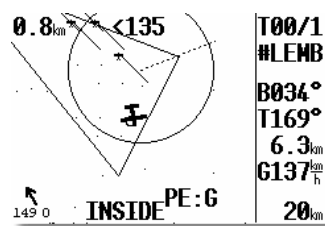

The most important distinction between auto and manual move is this that after manual use predicted ATA/ETE and distance will be offered and by auto move momentary situation is taken in account.

Once the task has been started, the **MOVE** function is immediately available for the actual TP on pressing ENTER, irrespective of which navigation page is selected.

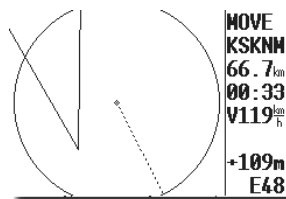

To move TP use ⬆ (radius) and ZOOM (rotate).



**Note!**  
It is recommended to **observe average speed** during move procedure to keep speed realistic.

**Switch over procedure after move has been used**

To change over to next TP a short press on **START button is absolutely** necessary, after the glider position is still inside the sector. MOVE doesn't matter.

**Note!**

After MOVE **had been used** and, the START pressed the **actual glider position** will be taken as an AAT turn point (some kind of automatic move) . This will **ensure realistic** ETA, ETE, remained distance and required average speed data. If there was no MOVE at all, the **default TP** data will be taken in calculation and such a situation will cause wrong statistics information.

Generally it is not necessary **to fly close** to the moved point. A decision to switch over to next point may happen anywhere in the sector. This act will **immediately update** the task and also ETA, ETE, the distance and required average speed to reach finish.

**Example:**

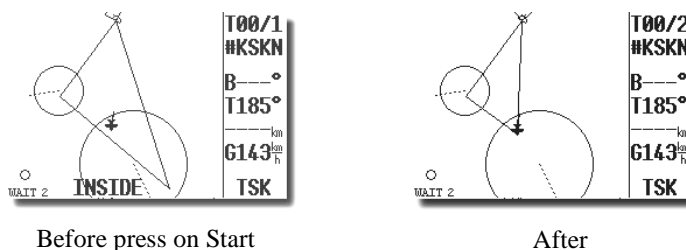

**Voice!**  
Next turn point

**3.3.5 Statistics during flight**

A few seconds after take off the **logbook page** will be replaced with statistics page. The statistics will inform about some important data special, if a task is flown.

The first page of Statistics mode is always active and shows take off time and the duration.

Rotating of ↻ will select individual leg statistics data and the last page is always task statistics data. This page includes a very important data about average speed from start until instantaneous position.

**Note!**

The task **start time** will be set automatically and will correspond to the last fix data inside the sector. It doesn't depend on time at which the start button has been **pressed**.

### 3.3.6 Task end

On entering the finish zone the task stops automatically and a message **TSK END** will appear. If you want to fly a new task without landing, then it is necessary to use **RESTART** and **SELECT**. If the **MOVE** function has been used on the **finish point**, then it will be necessary to finish the task by using the **START** button as in the **AAT** sector.

#### Note!

If the finish regulations prescribe entering a cylinder, usually 2 km radius with a base of 200m, then program the finish zone to the cylinder parameters and set the safety altitude in **INIT** to the height of the base of the cylinder. When on the final glide, **MOVE** the finish point to the border of the cylinder and all it is then necessary to do is to fly the glider to keep the final glide deviation on 0m.

#### 3.3.6.1 Procedure after landing

IGC Regulations require a straight line (base line) in the barogram at the beginning and end of the flight. For this reason that it is recommended **not to switch off the unit OFF** immediately after landing, but to wait a few minutes. About 3 minutes after landing, the following message will appear on the screen:



Let the message time out a new message will appear saying that the **SECURITY** algorithm is being calculated. Pressing **ENTER** before the screen times out will allow the flight to continue until the unit is powered down.

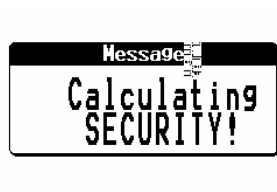

This message will remain for about one minute and during this time the instrument is writing the security information that validates the .IGC file. When it is finished, it is safe to switch off the instrument. Confirmation that the procedure is complete can be checked by selecting the **Statistics** page: if the **logbook** is shown, then the procedure is finished. **Never switch off the unit while it is CALCULATING SECURITY.** If the unit is accidentally switched off immediately after landing, it will not cause any problem. When switched ON again, the calculating security message will appear for a minute or so.

#### 3.3.6.2 Downloading of flights

The simplest way is using of SD card. Otherwise the pilot has to use PDA or PC. See capture Communication.

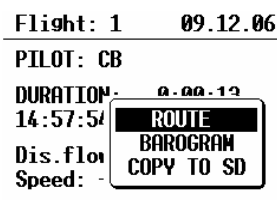

### 3.3.7 SIMPLE TASK (flying around TPs or APTs )

The simple task feature is active prior to a **regular task being started**. The feature is very useful for pilots who do not fly tasks but fly from TP to TP (or to an APT). Simple task **permits statistics** to be stored like a real task and which can be displayed on the Statistics page and also evaluated by a PC after flight.

Immediately after take off, the **current position** will be considered to be a **start point**. On reaching a TP or APT which has been selected in TP or APT mode, the point will be treated as a confirmed TP in a simple task and so on. If there is no TP or APT close, a marker setting will substitute the missing turnpoint. A short press on **Start** in upper navigation page of TP will set a marker.

STATISTICS	
TSK S/1: THALMAES	
Time:	0:52:19
Duration:	0:08:11
Speed:	126 <sup>km</sup> / <sub>h</sub>
Vario:	---% 0%
Engine:	-'--"

To perform more **realistic situation**, the pilot is able to define his start position any time. After RESTART, the **position at the time** of the restart will be taken as new start point of a simple task.

**Voice!**  
Near.

#### 3.3.7.1 Distance Measuring Equipment

This function is specially developed for those pilots who don't use task mode flying cross county flights, but they want to know how many kilometers they have **done** and how many will be, if they **turn back to home**.

AJDNA			TP
ACT T.	ETE	ETA	
08:26	02:31	10:57	
Distance done:		31.6 <sup>km</sup>	
Tot.dis. to home:		63.3 <sup>km</sup>	
Wind WAIT 2			
OAT +26 C	BAT 13.6V		

Pilot has in fact no influence on this calculation, it is only important to select turnpoint or airport and to near the point. Having no close APT or TP a marker setting will set a temporary turnpoint.

**Start position** is takeoff and also "Home" is the same position. Both points are set automatically. What actually the pilot has to do is to become **near** to the TP or APT. In case of no near APT or TP a manual **Marker** setting will substitute a real TP. Marker can be easily set after short press on Start button in TP mode.

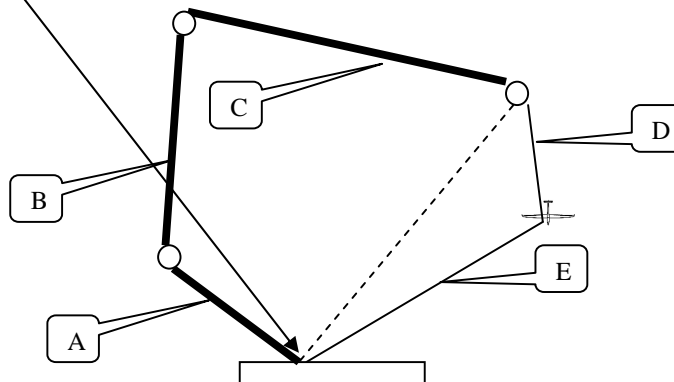

Bold lines (A,B,and C) illustrate already done legs which distances are fix. Legs D and C is flexible, as the pilot didn't set any marker.

Distance done: A+B+C+D

Total distance to home: A+B+C+D+E

**Note!**  
Restart will not influence home position, it will influence only start position.

### 3.3.8 Climb indicator

Some additionally help was developed to make pilots searching for the centre of climbing easier.

- After lowest ZOOM, rotate one step to the right and a special graphic page called CLIMB will open.  
A glider symbol with its route done in the last 60 seconds will be present, each second one sample. Additionally to the position data vario is sampled and a maximum is calculated. The maximum is designated like dot with the biggest diameter. The pilot should steer to fly into this area.

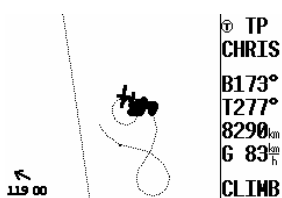

The area is 700 x 700 big.

- The second variant is in the first navigation page.

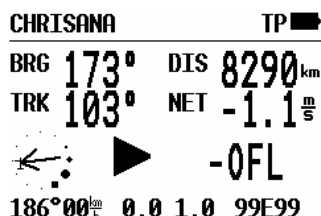

Around the wind vector is build a circular display which dots shows vario samples. The same philosophy like by CLIMB display was taken and the fattest dot shows vario maximum. A small glider symbol is positioned always on the left or on the right side and its position is always stable. During right circles the symbol will be on the left side and vice versa. The pilot should imagine his position in the glider symbol and wait until vario maximum will meet the glider. The wind vector isn't involved.

### 3.3.9 Altitude Gain indicator and Total Averager

LX 7007 1.2 has got two additionally extremely useable functions.

### 3.3.9.1 Altitude Gain indicator

As the glider will **start circling** the altitude gain indicator will become active and will show continuously **altitude gain** of the actual thermal. The circling detection runs automatically and the pilot isn't able to influence the process.

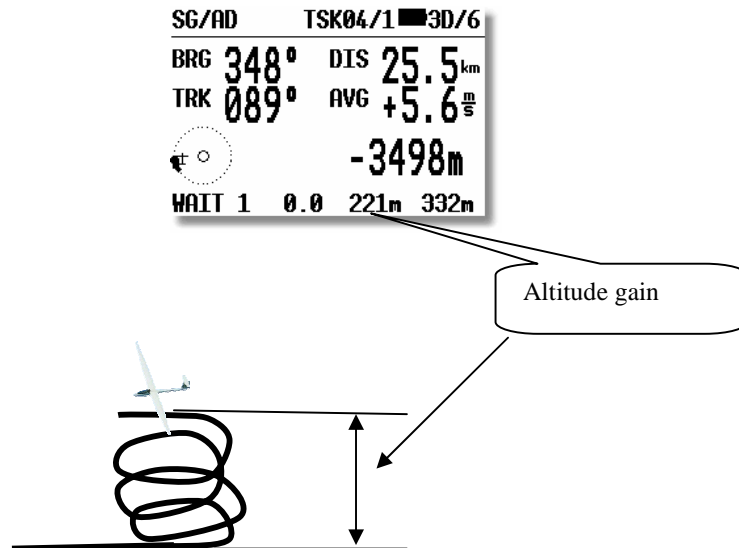

As the glider will leave the thermal and will continue straight away a total average of the last thermal will be shown until next circling.

### 3.3.9.2 Total Averager

This information is also available in the first navigation page of APT, TP or TSK, exclusively during straight flight. VAR/SC status doesn't matter. A **T** accompanied with figure shows division of altitude gain and time spent in the last thermal.

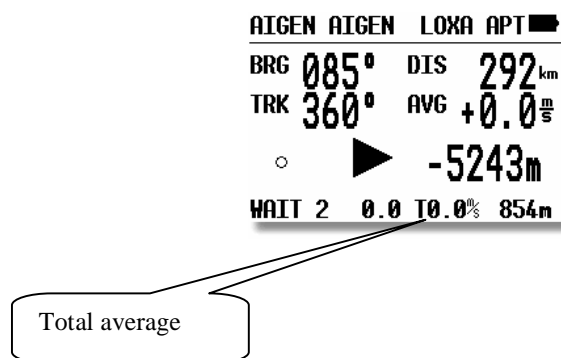

Total average may be also inquired during climbing period, it is necessary to switch into SC for a short time.

### 3.3.10 Using of PDA like secondary navigation system

Many PDA running programs will operate using NMEA data send out of LX 7007 PDA interface. Additionally data sentences including altitude, vario, task data, etc. to drive LX Mobile, SeeYou Mobile, Winpilot or Navigator are active after appropriate setting in Setup of LX 7007.

A suitable PDA program called **LX Mobile** was developed to optimise interaction LX 7007 – PDA. Using of this program will save a lot of pilot's time, while LX Mobile practically doesn't need any manipulation during the flight.

**Note!**

LX Mobile is a part of delivery, available on CD and delivered with the unit for free.

#### 3.3.10.1 LX Mobile features

The NMEA sentences sent out of PDA interface includes additionally **task data**. Immediately after a task has been selected on LX 7007, doesn't matter started or not, the task data will be sent like an additionally so called LXTSK data sentence toward PDA. LX Mobile will build the task on PDA display, including all legs and **observation zones**. All task modifications done on LX 7007 during flight, including observations zones changes (ZONE and MOVE) will be updated automatically without any manipulation on PDA. There is no way to modify LX 7007 task from PDA.

**Note!**

Use following NMEA data sentences to run LX Mobile:  
GGA, RMC, LXWP\_ and LXTSK

LX Mobile offers following:



- LX 7007 active task monitoring on PDA
- Display of turn points
- Airspace display with warnings
- Vector map background
- Display of terrain

#### 3.3.10.1.1 LXMobile installation

Use LX Mobile manual, available on CD delivered with LX 7007 or use internet.

## 4 Communication with PC, PDA, Colibri/LX20 and SD Card

**Note!**

The unit is able to **adapt automatically** to the baud rate of the partner unit, so no more problems, if both units don't have the same baud rate. A very typical message **AUTODETECT** will inform about searching for synchronization. After synchronization is established a **CONNECT** status will appear.

The LX 7007 PRO IGC is able to communicate with a:

- PC, using LXe, SeeYou or Strepla .
- SD card, if card reader/writer build in
- PDA, ConnectLX, Downloader
- LX 20
- Colibri
- Posigraph

**Note!**

The unit is equipped with three **physically separated** com ports, which means no data collision even all possible devices connected and switched on.

Using of LX7007 PRO IGC in conjunction with a LX20 or Colibri, is possible to prepare a flight at home or during the competition briefing, and then when at the airfield use the LX20 or Colibri as a data source for LX 7007 PRO IGC. Similarly, a task can be programmed in a PC and then transferred to a LX20 or Colibri for subsequent loading into the LX7000 PRO IGC.

Using of a PDA will do the same, but additionally offers downloading of flights, which means practically no use of PC in cockpit any more. Flying a competition PDA can be used like data transportation medium Glider – Scoring office, while the flights stored in PDA includes **secure data**.

A CD with the following programs is supplied with LX 7007 PRO IGC:

- **LXe** Windows program for communication, basic flight evaluation and database management.
- **LXMobile** moving map PDA program, manual and program available on LXe CD.
- **LxasBrowser** for airspace management and its manual.
- **ConnectLX/connectMe** for data transfer LX 7007 - PDA.

## 4.1 Communication with PC

After PC communication art was chosen by the pilot, a PC connected to the **5P round** connector, normally positioned on the instrument panel, can do this job. All kinds of PC communication can also be provided after using of **IGC port** which is available on the rear side of he unit. Use IGC standard cables.

**Note!**

The LX 7007 pro IGC uses **.CUB** format of airspace data structure. Ensure that the version of LXe used to load airspace is build **13 January 2006** or later; never use old versions of LXe to load airspace.

Communication with a PC is via the RS232 serial COM port. If your computer only has an USB port and no real serial COM port, then you will need to obtain an USB to serial adapter, available in every computer shop. To couple the unit to the COM port, a special cable is supplied with the LX 7007 PRO IGC which terminates in a SUB D 9 pin socket, on the PC side.

A CD with the following programs is supplied with LX 7007 PRO IGC:

- **LXe** Windows program for communication, basic flight evaluation and database management. The user manual is available on LXe CD or [www.lxnavigation.si](http://www.lxnavigation.si).
- **LXMobile** moving map PDA program
- **LxasBrowser** for airspace management and its manual.
- **ConnectLX** for communication with PDA

Using the LXe program, the following procedures can be carried out:

- Read logger
- Read \*.da4 (TP and TSK files)
- Read flight info
- Write \*.da4 (TP and TSK files)
- Write flight info \*.hdr
- Write APT
- Write airspace (**.CUB** files only)

LXe **will automatically recognise** an instrument requesting **.CUB** file and will offer browse function to find adequate **.CUB** airspace file. All 6 sections of the airspace could be transferred in one shot. The procedure:

Another very useful function of LXe is the preparation of task details such as start, TP and finish sectors. Using the menu **ZONES** in Lxe, the details of AAT sectors can also be programmed. All this data can then be transferred to the LX7000 PRO IGC.

LXe can also be used to update the APT and airspace database. Such updates are free and **no update code** is necessary any more.

**Note!**

LX 7007 has a memory capacity to store maximal 6 **.CUB** airspace files. To replace one section with another simple load a new one. Flying a competition where some special versions of airspace are issued, overwrite the airspace, which you normally don't use, to prevent missing of airspace data after returning home.

The CONNECT status is achieved as follows:

- **On the PC run program LXe**
- **On the LX 7007 PRO IGC go to SETUP – TRANSFER /PC PORT**
- **On the LX 7007 PRO IGC press ENTER and wait some seconds until AUTOCONNECT finish and CONNECT appears**

**CONNECT** indicates that both LX 7007 PRO IGC and PC have established Cconnection and are ready for data exchange.



### 4.1.1 Downloading of Flights

After CONECT status has been established, **Transfer** window on PC will become active. After click on Transfer (left mouse) and selection of Read Log Book the log book will be downloaded. Use left mouse click on the flight of interest to start download.

### 4.1.2 Transfer of TP/TSK data base and Flight Info

This kind of data transfer is bidirectional, means upload and download is possible.

TP/TSK data may be loaded exclusively in **.da4** format. The same is with Flight info data, this data should have **.hdr** format. Flight info data transfer to LX 7007 includes declaration also.

### 4.1.3 Upload of Airport data base

The airport data base transfer will start after WRITE APT command on PC. The data base version which will be loaded depends on selection in SETUP/Options (LXe),

### 4.1.4 Loading of airspace sections

LX 7007 has capacity to store up to six sections of airspace. All sections can be loaded in one shot, use LXe build on Jan. 13<sup>th</sup> 2006 or later. The procedure:

- Establish **CONNECT**
- Press on **Transfer**
- Select **Write CUB** airspace and click on **CUB manager**

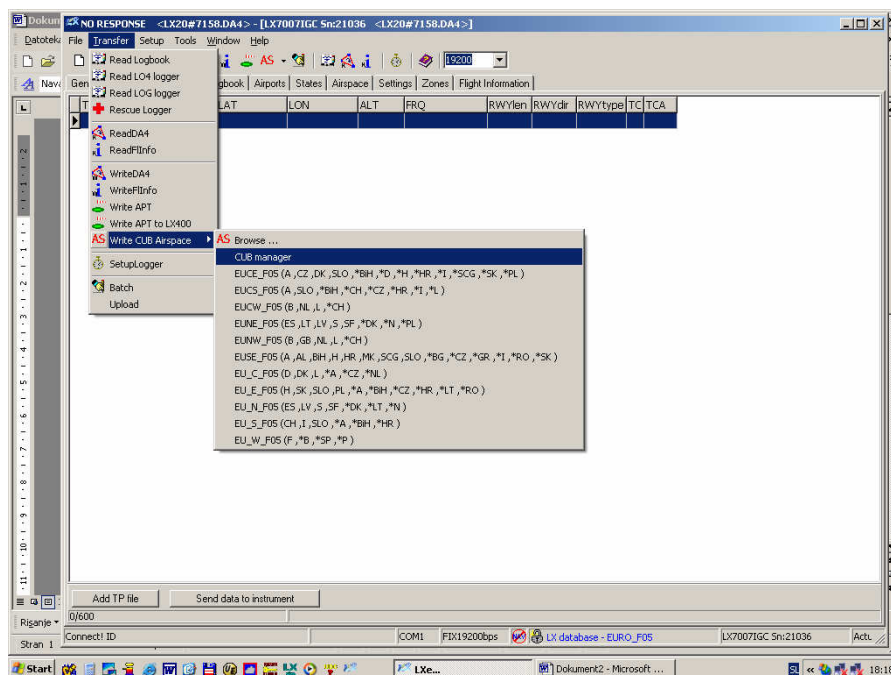

- All airspace sections already stored in the unit will be shown.

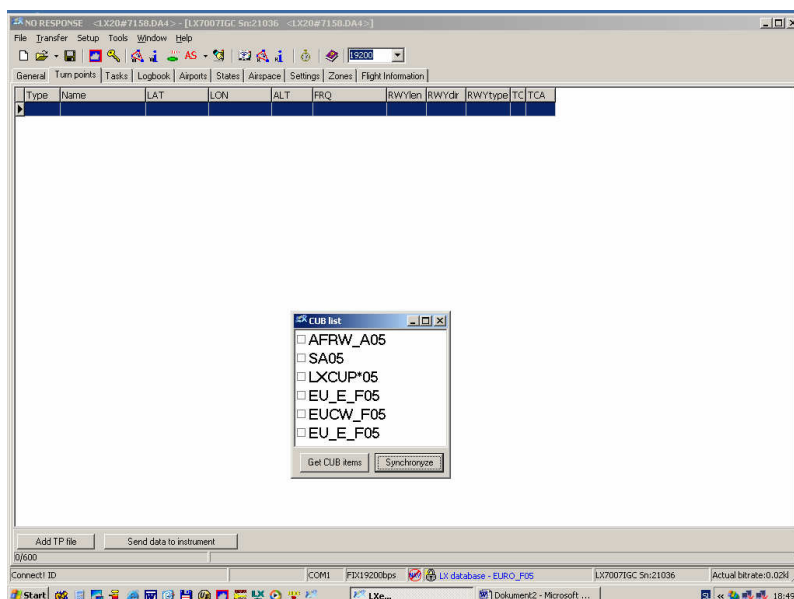

- Use right mouse click on airspace which you want to replace, a browse function will allow you to select any **.cub**.
- Press on **Synchronyze** to transfer checked files into LX 7007.

### 4.1.5 IGC Shell program

IGC Shell program (developed by IGC) in conjunction with **LXN-IGC.DLL** can be used for flight download, conversion to IGC format and for flight validation. Both programs are available on [www.fai.org/gliding/gnss/freeware.asp](http://www.fai.org/gliding/gnss/freeware.asp). This kind of communication is mostly used by competitions, for private use we recommend LXe.

### 4.1.6 Some help having problems with communication

#### 4.1.6.1 General

90% or more problems causes from PC side. Practically no problems on LX hardware found till now. Having mentioned problems, please go carefully through that document, having too little knowledge about PC operating system, please contact experts.

#### Troubleshooting with LXE

- Available communication ports for LXE (Setup→Comm. Port)

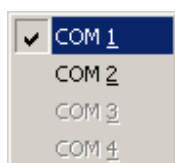

Highlighted ports are ready to be selected.  
 Means that LXe will use checked port for communication with LX, there is no automatically selection by LXe. Selection of comm. port should be done after first run of LXe.

- No ports available

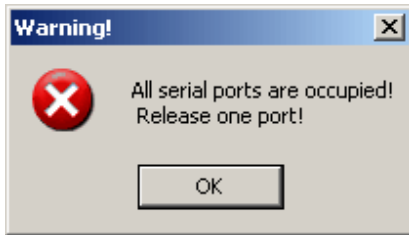

After such message, no communication will be possible.

Reasons:

- **PC has no serial ports** (LAPTOP with USB only – the only solution is USB to RS232 adapter – available in computer shops – necessary to install drivers  
USB-232 adapter should be plugged in **before starting LXe**)
- Ports are occupied by another applications – programs (E.g. Active sync program for communication with PDA's)

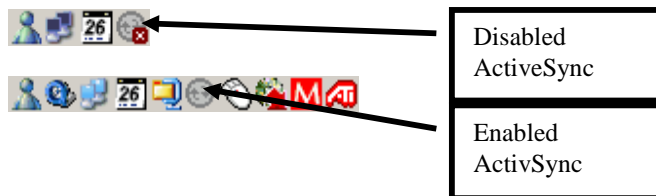

How to disable Active Sync?

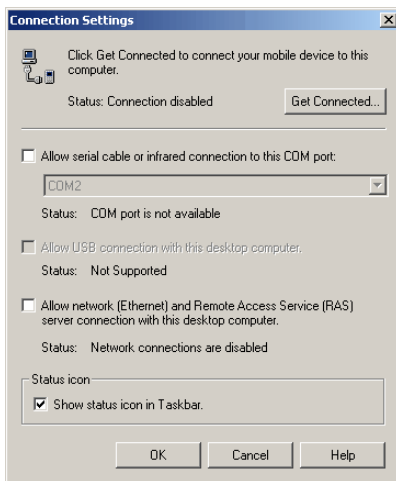

After right mouse click on ActiveSync symbol in task bar, choose *Connection settings...* and disable it. (PC's with only one comm. port).

Problems caused by USB to 232 adapters.

Normally PC has more than one USB port. On first use of USB/232 adapter, operating system will detect new USB device. Wizard will guide you through setup process of drivers for specified USB/232 adapter. After successfully installation of USB driver Lxe will detect new additional comm. port. Usually the number of new comport is higher than 4. (COM5, COM6...)

It's recommended to use always the same USB port on PC (physically). If you use another USB port, new installation of USB/232 driver will be necessary. Operating system will add next free communication port.

**4.1.6.2 Recommended LXE settings for safe communication**

- Fixed baud rate
- 19200 bps
- Keep Connected during preparation....

**4.1.7 Having problems downloading flights (read selected flight-command).**

Symptoms:

- Baud rate speed is not constant (oscillating from 0k to 19k)

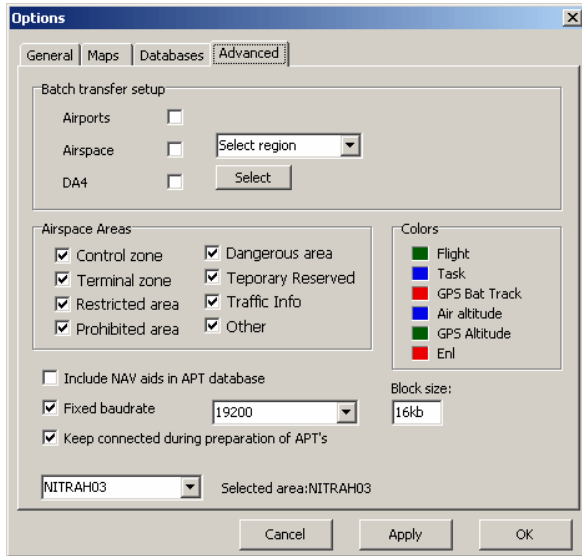

- More retries downloading blocks

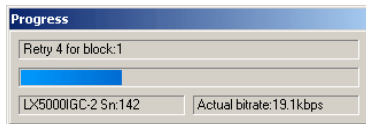

Result could be unsuccessful downloading of the flight.

Workaround:

- Reduce communication speed to 9600 bps or lower and do the same on LX unit. (that is a typical problem by laptops using USB adapter )
- Reduce block size (Options/ Advanced)

**4.1.8 Additional help from LX navigation**

Haven't found any solution, please use *Help*→*Troubleshooting* form of Lxe and send it to [support@lxnavigation.si](mailto:support@lxnavigation.si)

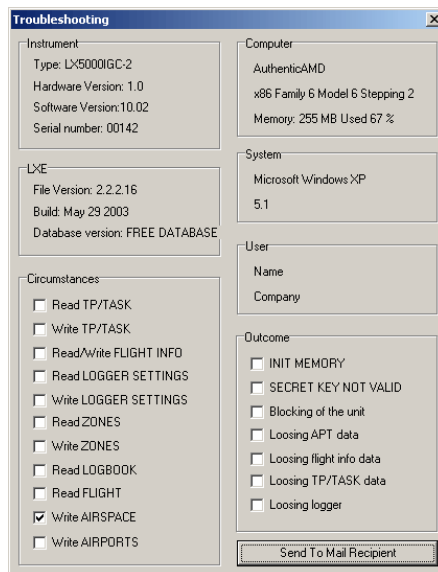

## 4.2 Communication with PDA

A completely separated com. port with his own 9P sub D Connector is situated on the rear side of the unit. LX 7007 has a built in DC/DC converter which ensures 5V power for PDA. A standard LX cable (**1638 or 1636**) will connect practically all iPAQ devices to LX 7007 without any additionally works. Main functionality of the port:

- Sending of NMEA data to PDA, see capture SETUP/NMEA
- Exchanging of data LX 7007 – PDA including **flight downloading**

Use free PDA program **ConnectLX/ConnectMe** or Downloader from FlywithCE.

**Note!**  
Cable to Connect LX 7007 and nearly all types of iPAQ is delivery included,  
**Cable LX 1638 will connect:**  
H22xx, H38xx, H39xx, H41xx, H43xx, H51xx, H54xx in H55xx, H4700  
**Cable 1636 will Connect:**  
36xx, 37xx,31xx

Users who didn't install 1638 or 1636 cable, means they don't use PDA as a secondary navigation system, are able to connect PDA via 5P round connector which is normally used for PC communication. In that case a 536 or 538 cable should be ordered. Using of this situation **PC port** and not **PDA port** on LX 7007 should be activated during connect procedure.

Using of third party PDA programs check their functionality at first.

### 4.2.1 Using of ConnectLX/ConnectMe

Run **ConnectLX/ConnectMe** and select Device type like COLIBRI....LX7000, **define com port** ( com 1) and other necessary parameters; suggested com speed is 19200 bps.

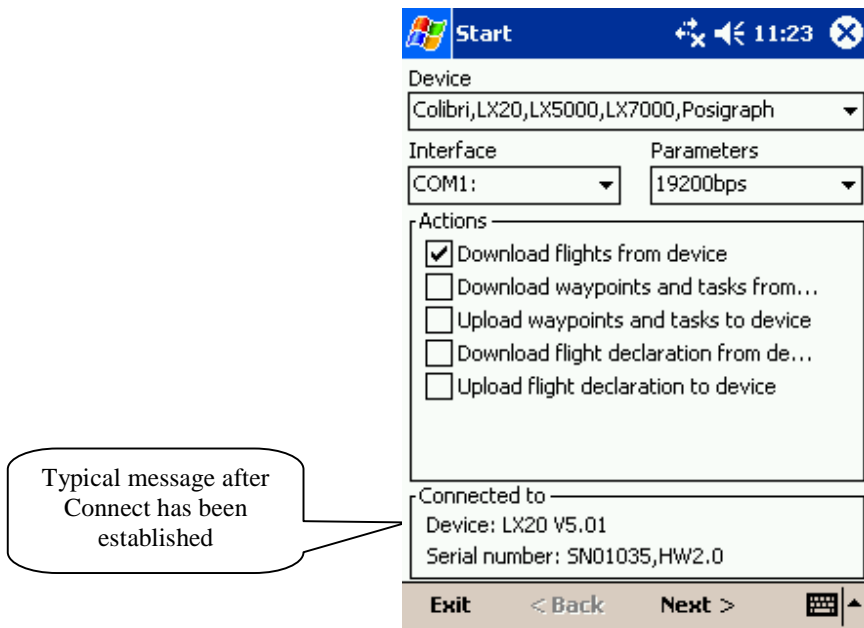

**Procedure on LX 7007:**

Select **TRANSFER/PDA** on LX 7007 and press Enter. After AUTODECT procedure, a very typical message **CONNECT** will appear on the LX 7007 screen.

**Note!**

Never run TRANSFER on LX 7007, before PDA is ready for communication

Define art of transfer using **Actions** menu on PDA and proceed with **Next**. For details see ConnectMe manual on [www.seeyou.ws](http://www.seeyou.ws).

**Note!**

Having problems **with connection to PDA**; make sure those other applications like SeeYou Mobile..... are regularly closed, otherwise they **occupies the com port**. Close the applications using **EXIT**.  
After any success, use **reset button on your PDA**.

**Note!**

TP/TSK files (**Upload waypoints and tasks to device**) can be uploaded to the LX7007 in **.da4** (LX format) or in **.cup** (SeeYou format). This allows using SeeYou mobile for TP/TSK file creation and ConnectLX/ConnectMe for uploading.  
Using this way the conversion **.cup ► .da4** will be done automatically.  
Respect LX 7007 TP capacity!

**1.1.1.1 Flight downloading using of PDA**

Recommended program is ConnectMe/ConnectLx. The connect procedure is the same as described in 4.21. See also ConnectMe manual. Use **Download flights from device** option, and follow Connect/Me instructions.

**Note!**

Recommended PDA settings:

- Device type: Colibri, LX20, LX 5000, LX 7000.....
- COM1
- 19200 bps

**4.2.1.1 Airspace and Airport data base transfer**

There is no way to transfer mentioned data into LX 7007 after using of PDA.

## 4.3 Communication between LX 7007, Colibri or LX 20

The LX 7007 PRO IGC is able to exchange data (bi-directional) with the LX 20, Colibri and Posigraph. The following data can be transferred:

- \*.DA4 files (TP and TSK)
- **Flight info** including task declaration
- Observation **zones** (ZONES)

**Note!**

LX 7007 powers Colibri or LX 20-2000 units connected to the LX 7007 IGC port. For older LX 20 versions order appropriate cable.

### 4.3.1 Data transfer LX 7007-LX 20

To establish data transfer with the LX20 use the following steps:

STEP	LX 20	LX 7007 PRO IGC
1	Main MENU / <b>LOGGER</b>	<b>SETUP / TRANSFER/COLIBRI/LX20</b>
2		<b>ENTER</b>
3	<b>READ or WRITE key</b>	<b>Select transfer function</b>
4		<b>ENTER</b>

The LX 7007 PRO IGC acts **as a master** device and forces the LX 20 to respond to the commands.

Transfer menu on LX 7007 PRO IGC

<b>READ TP/TSK</b>
<b>READ INFO</b>
<b>READ ZONES</b>
<b>WRITE TP/TSK</b>
<b>WRITE INFO</b>
<b>WRITE ZONES</b>

**Read** means LX 7007 PRO IGC will read data from LX 20 or Colibri and vice versa.

Read zones means copy of confirmation zones architecture from Colibri or LX 20 and write means vice versa.

Write setup will write logger setup (recording intervals etc) from LX 7007 pro IGC into LX20 or Colibri.

After Read/Write INFO data transfer, the flight declaration including pilot data will be transferred.

**Note!**

To Connect LX 20-2000 use cable delivered with LX 7007, the cable should be plugged into IGC marked telephone type Connector. Using of 6 pole cable doesn't matter. Having an older unit order an adequate cable

### 4.3.2 Data transfer LX 7007-Colibri

Communication with a Colibri or Posigraph recorder is much simpler. The Colibri or Posigraph will **CONNECT** automatically after selecting **TRANSFER/COLIBRI/LX 20** then **ENTER** on the LX 7007 PRO IGC. The **CONNECT** status is signalled by a series of audio beeps from the Colibri or Posigraph. LX 7007 will act as a master. The same features like by communication with LX 20 are available.

**Note!**

To connect Colibri use cable delivered with LX 7007, the cable should be plugged into IGC marked telephone type connector. Using of 6 pole cable doesn't matter. Using of this configuration will also power Colibri from LX 7007.

## 4.4 Data transfer after using of SD card

This is the simplest and safest way how to get data into and out of LX 7007. All units delivered after September 2006 is already equipped with SD card slot. All older LX 7007 units are simple upgradeable. Every SD card delivered with the instrument is already initialized and ready for operation. The card will be normally found on PC as Removable Disc. The card structure:

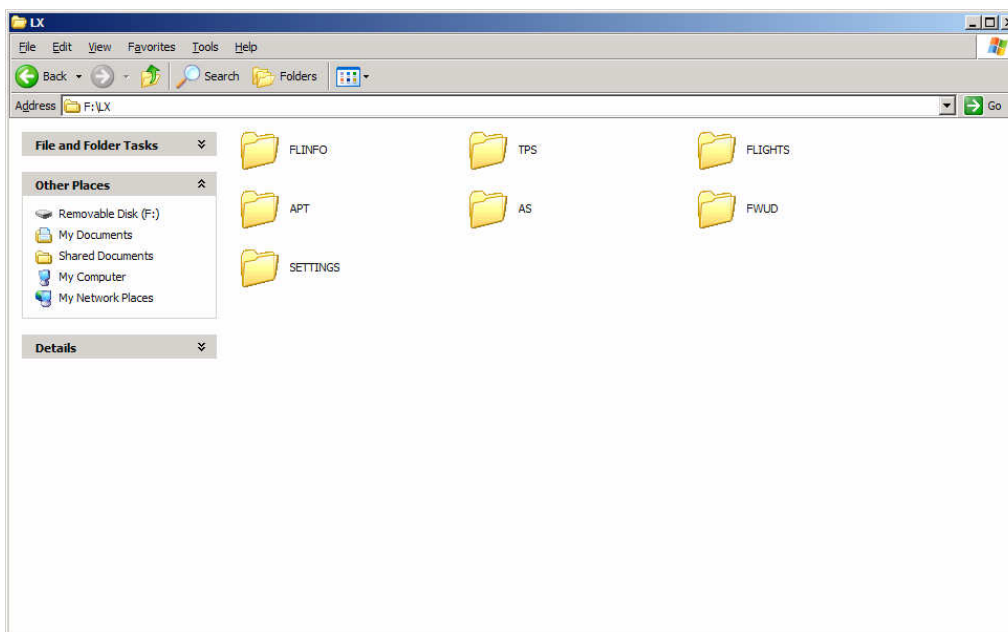

Use Windows copy commands to carry data from hard disc to the SD card. Respect that the individual files should be copied into corresponding folders.

### 4.4.1 Data base data exchange

Select TRANSFER and use option SD/MMC. A very obvious menu will open:

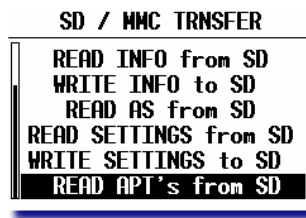
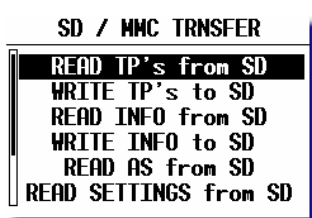

After item selection and Enter the data exchange procedure will start. Any data exchange is extremely fast and needs typically some seconds.

**Note!**

To leave menu use exclusively **ESCAPE**.



Please respect following restrictions:

- TP/TSK data format **.da4** (LX format) or **.cup** (SeeYou format)
- Flight Info format **.hdr** (LX format), this type of file can be prepared with LXe and copied to SD, this info could also include task declaration data
- Airspace **.cub** format (use LX original files, SeeYou files are not compatible)

Note!

If **.cup** file consist of more than 600 turnpoints or 100 tasks the number will be reduced to 600 and 100 automatically.

Use **Export** function of LXe to copy any **.cub** airspace file to the SD card..

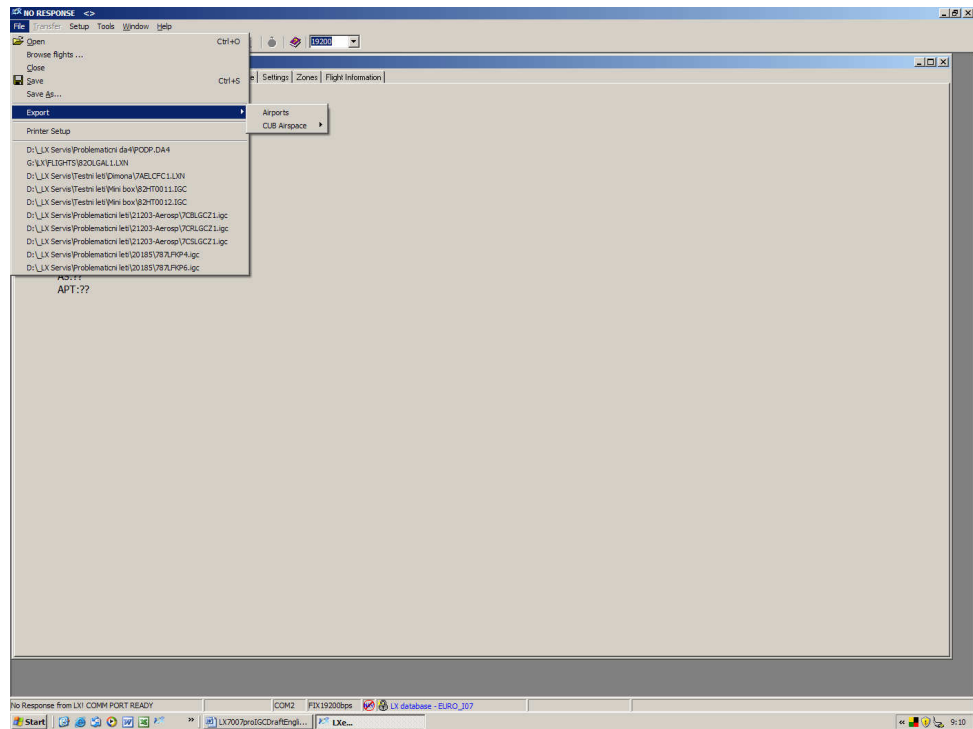

- Settings are not able to be prepared or edit on PC, it is only possible to store actual personal settings and to reload them back
- Airport data base in **.LXA** format. Any LX airport data base may be converted to **.LXA** format after using of LXe EXPORT function. Click on File and confirm Export.

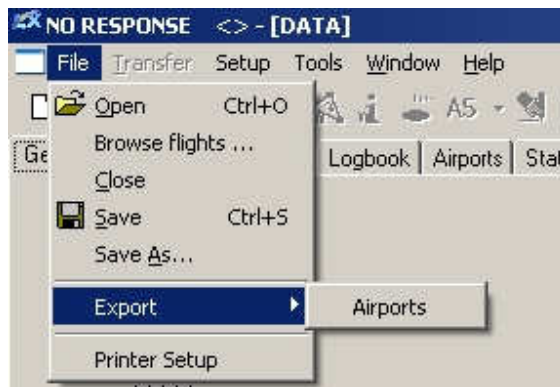

Example of TP/TSK data transfer:



Example of .da4 transfer direction SD card ⇒ LX 7007

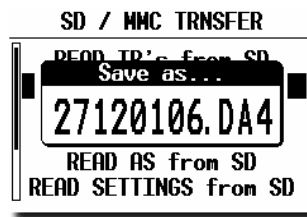

Example of .da4 transfer direction LX 7007 ⇒ SD card  
(ESC will confirm offered name)

**Note!**

After **Write to SD** command has been activated, a file name consists of date and time will be offered. The name can be directly modified by user.

After **Read command** all files of the directory will be offered and selection should be carried out.

#### 4.4.2 Downloading of flights

Any flight from LX 7007 **Logbook** can be any time downloaded to the card. After Enter on flight of interest use COPY TO SD command.

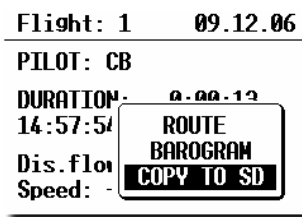

After Enter the flight will be copied to SD card. The procedure will take some seconds.

**Note!**

The file saved on the card will be in **.IGC** format and also in LX original **.LXN** format.

## 5 Installation

The LX 7007 PRO IGC main unit (LX 7000 DU) needs one standard 80mm cut-out. The Vario sensor unit (LX 7007 AU) and any additional vario indicators need a standard 57mm cut-out each.

Three pressure Connectors are fitted to the back of the LX 7007 AU. **A label shows their functions.**

- Ptot = Pitot or Total pressure
- TE = TE probe
- Pst = Static

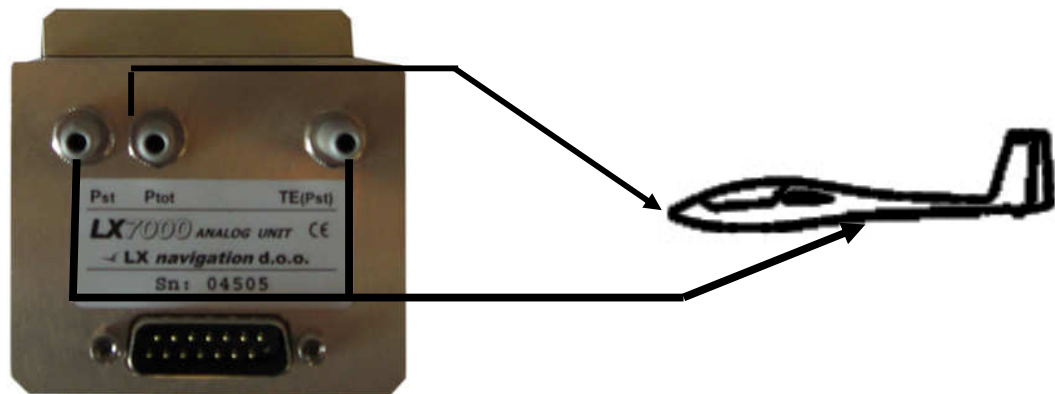

If the unit is to be configured for electronic TE compensation, then the Connections are as follows:

- TE/Pst Static
- Pst Static
- Ptot Pitot or Total pressure

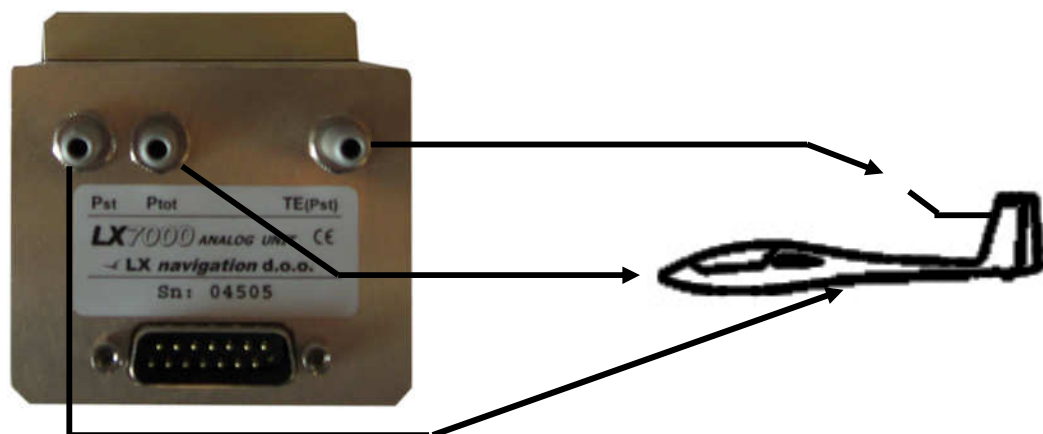

If the unit is to be configured for pneumatic TE compensation using a TE tube, then the Connections are:

- TE/Pst TE tube
- Pst Static
- Ptot Pitot or Total pressure

**Note!**

If the Ptot and Static are connected **the wrong way around**, there will be no integrator reading (average climb) during the flight. The LX 7007 DU (80 mm unit) is connected to 12 volt power via the 15 SUB D connector. LX 7007 DU and LX 7007 AU (57 mm ) units are connected via the 485 bus and the connectors are marked like **1-1**.

Please check, if both units are connected correctly, before **first power on**. The power wires (red and blue) **should be connected to the 80mm unit**.

**Note!**

There is **no fuse in the instrument** so it is **VERY IMPORTANT** to use an external fuse (max. 3A). Power supply cables should use a minimum of 0.5mm<sup>2</sup> wires (20 avg).

To prevent **damages on LX 7007 80mm** unit after a short on 485 bus, a fuse of blade type (the same fuses are used in modern cars and therefore available on petrol stations) is built on the rear side of the unit. After a short happened 57 mm unit will not work any more, but the reason is not the defect of 57mm unit, but the bowled fuse. Use **3 A** fast acting blade type fuse (violet).

**Installation of the LX 7007 PRO IGC**

- Prepare the cut-out in the instrument panel according to the drilling template.
- Remove the press-in covers from the four main selectors on the LX 7007 PRO IGC. You can now see the mounting screws.
- While holding the knobs, slacken the screws with a screwdriver. Now the knobs can be removed (never use power to remove the knobs, you can **damage rotary** switches). By problems **hit on the slacken screw** a little bit.
- Remove the four special type screws.
- Position the LX 7007 PRO IGC in the cut-out in the instrument panel.
- Tighten the LX 7007 PRO IGC with the special screws (8 mm tool).
- Tighten the knobs and replace the covers
- LX 7007 AU doesn't need any changes having standard 57 mm cut-out.

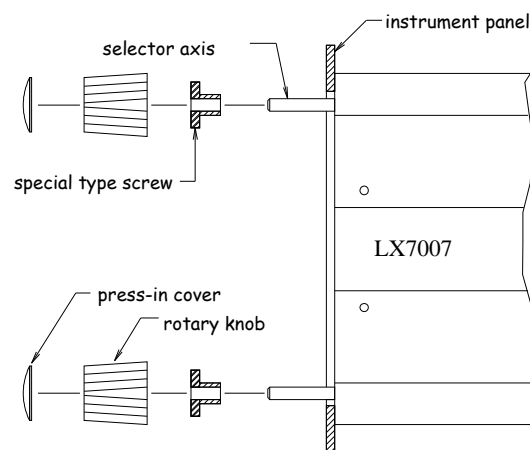

**Mounting Template:**

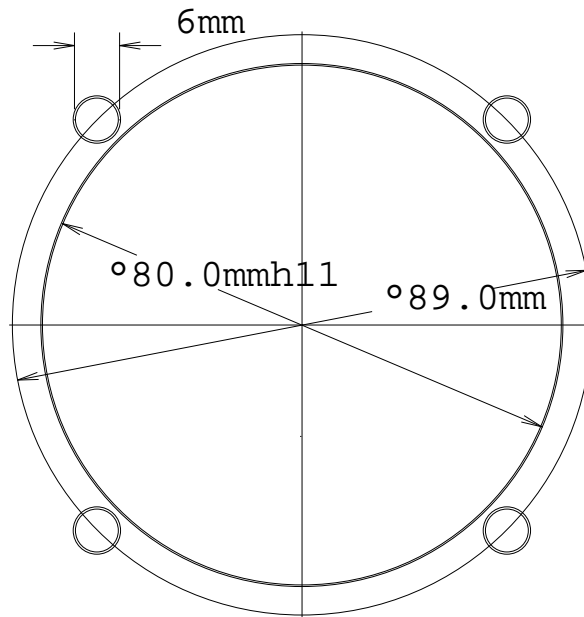

**5.1 Vario/SC external switch installation**

For this purpose an external switch usually installed on the top of the stick may be used. Flaps gliders uses some solution which closes or opens a contact as flaps is in circling position and vice versa. The configuration can be set in setup **INPUT**.

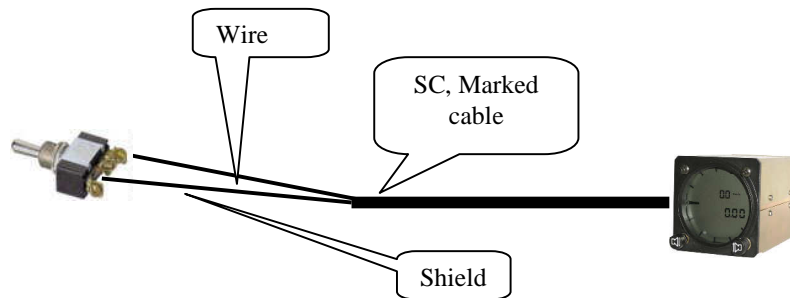

Wire	Shield	<b>Open</b>	Setting: ON	Staus: VAR
Wire	Shield	<b>Closed</b>	Setting: OFF	Staus: SC
Wire	Shield	<b>Closed</b>	Setting: ON	Staus: SC
Wire	Shield	<b>Open</b>	Setting: OFF	Staus: VAR

Setting **Taster**: will change over (SC/VAR) after each press on the push button. Set this after using of LX Remote.

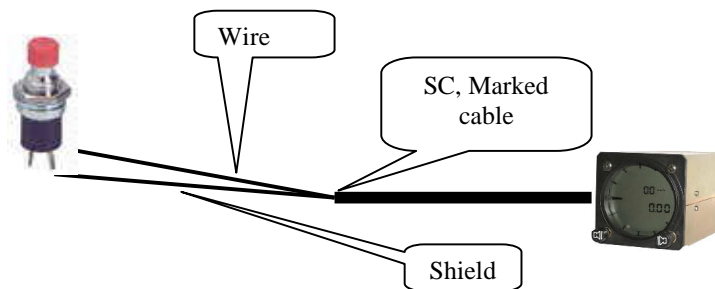

## **5.2 Installation of PDA units**

LX navigation offers a wide range of accessories which makes installation of a PDA in conjunction with LX 7007 extremely easy and completely plug and play. LX 7007 has a separate com port specially designed to drive PDA, 5V power for PDA is included. Using of LX standard cables is possible to connect practically all iPAQ units to LX 7007. A cable is delivery included. There are two types of cables.

Cable 1636 for:

31xx, 36xx, 37xx

Cable 1638 for:

H22xx, H38xx, H39xx, H41xx, H43xx, H51xx, H54xx in H55xx, H4700

There are two swivel supports available.

iPAQ Handle for:

36xx, 37xx, 31xx, H38xx, H39xx, H51xx, H54xx, H55xx, H4700

iPAQ handle 22 for:

H22xx, H41xx, H43xx

### 5.3 Installation of options

All options (LX 7007D, Remote Control, Voice Module, Compass Module, secondary vario indicators) are prepared to be connected to 485 system bus after using of 485 Splitting units. Installation of any option is plug\_and\_play and therefore requires only mechanic installation works. LX 7007 DU also powers all bus connected devices. A fuse built on LX 7007 DU back side prevents damages on DU after a short in wiring or in some device will happen.

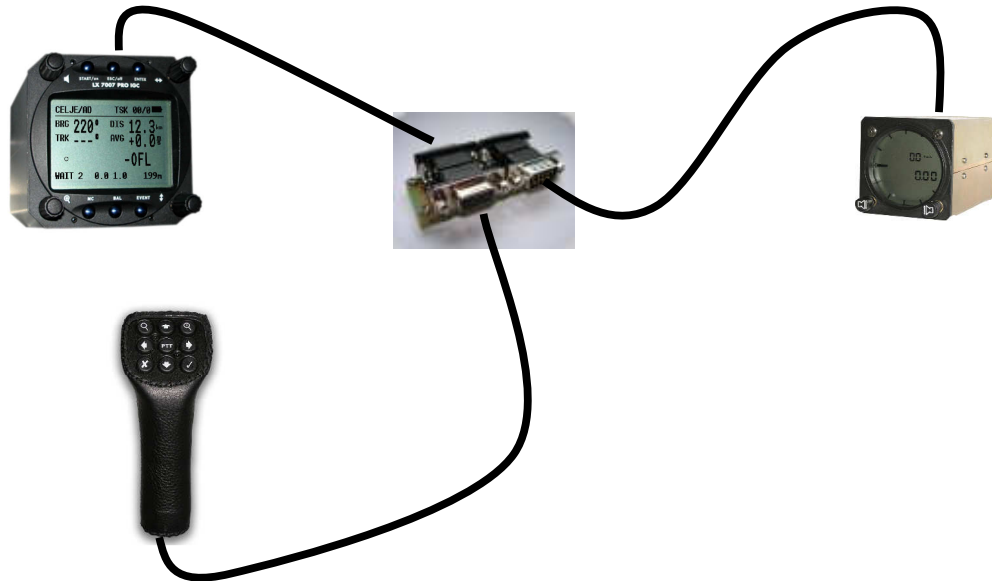

## 5.4 LX 7007 pro IGC full configuration

**BASIC CONFIGURATION**  
**EXTENDED CONFIGURATION**  
**REAR SEAT CONFIGURATION**

⊕ When using two 485 splitters order connection cable

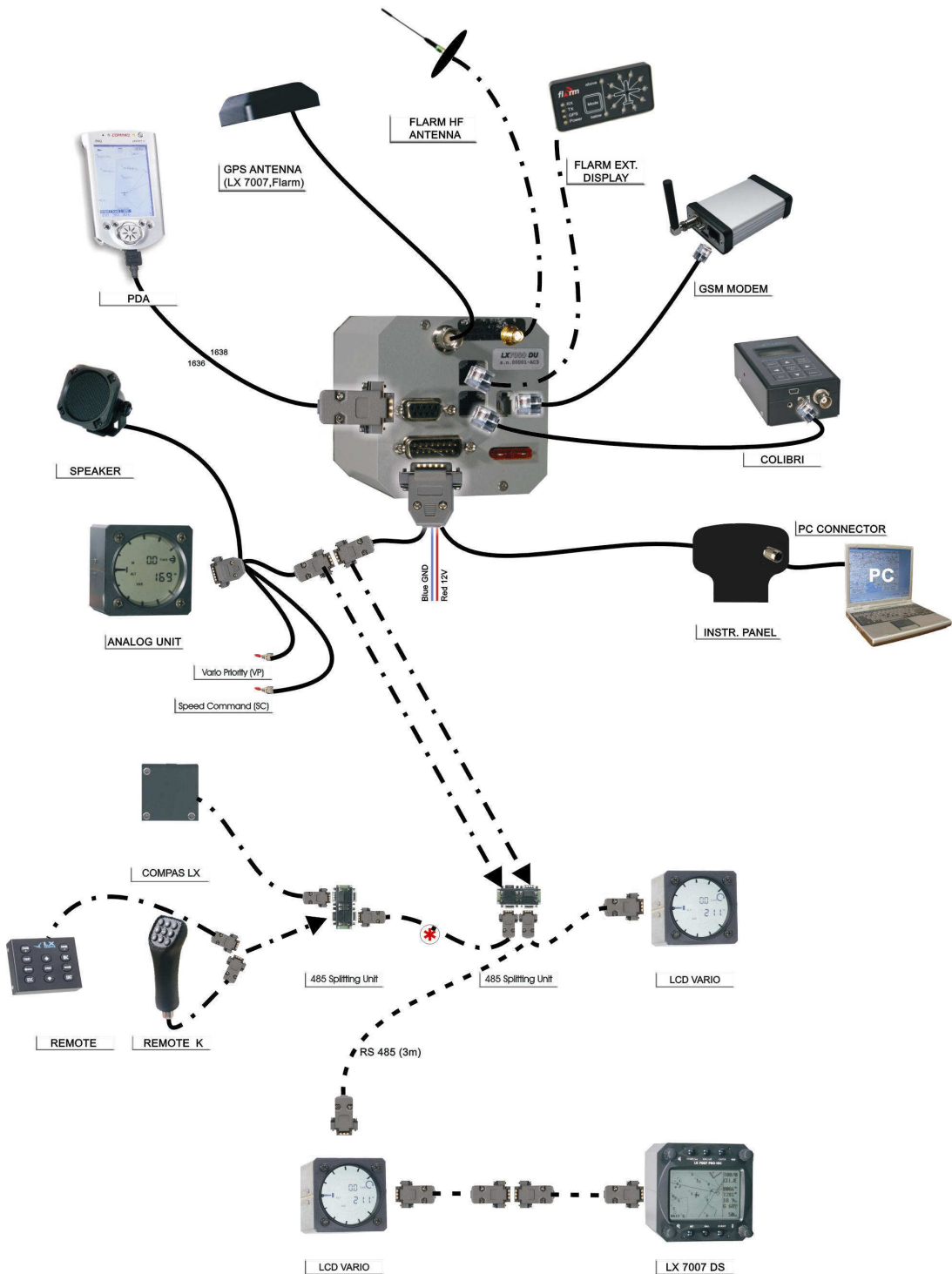





# 5.5 Wiring

## LX 7007 ANALOG UNIT Wiring

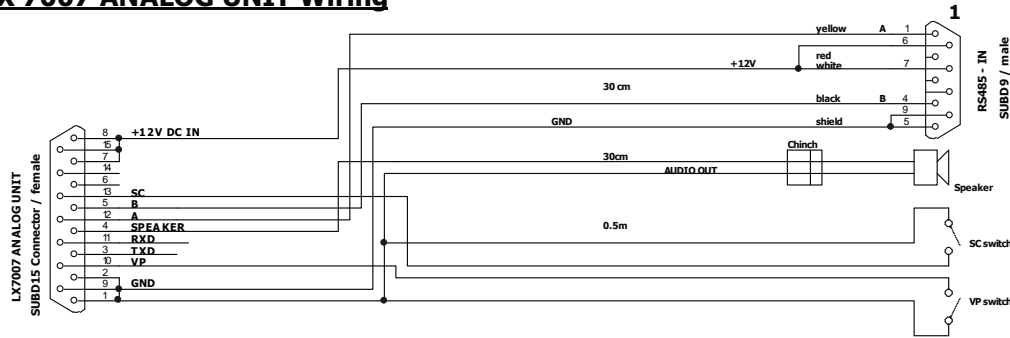

## LX 7007 DIGITAL UNIT Wiring

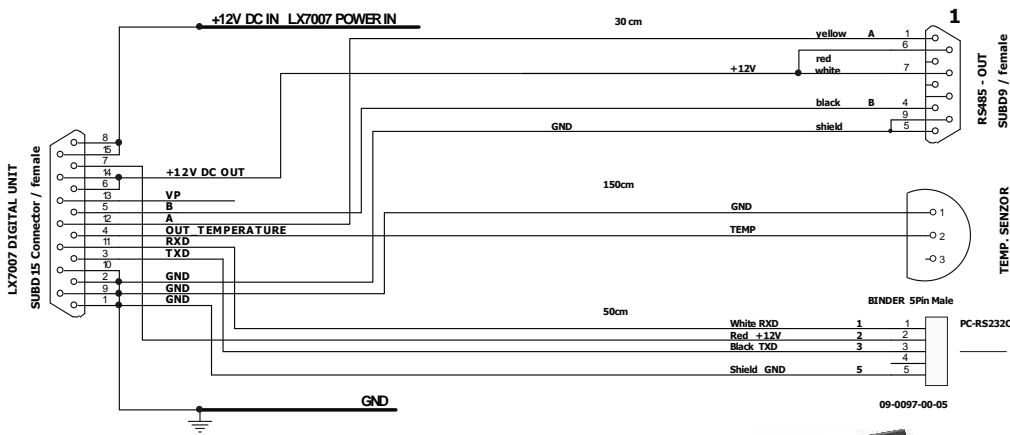

CONNECTED

### LX5PC CABLE

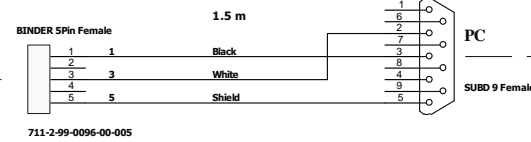

PC

### CABLE LX1636 / LX1638

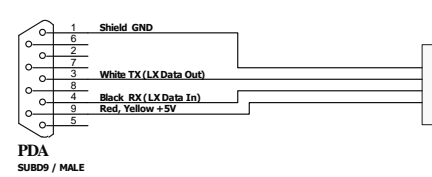

PDA

### LX7COL CABLE

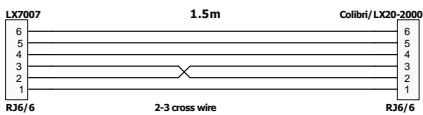

COLIBRI

OR



LX20-2000

**LX 7007 ANALOG UNIT Wiring**

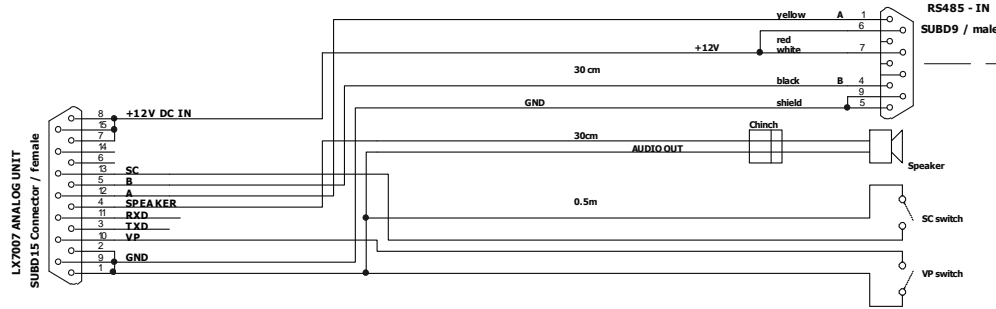

485 Splitting Unit (using additional LCD vario and Kompass)

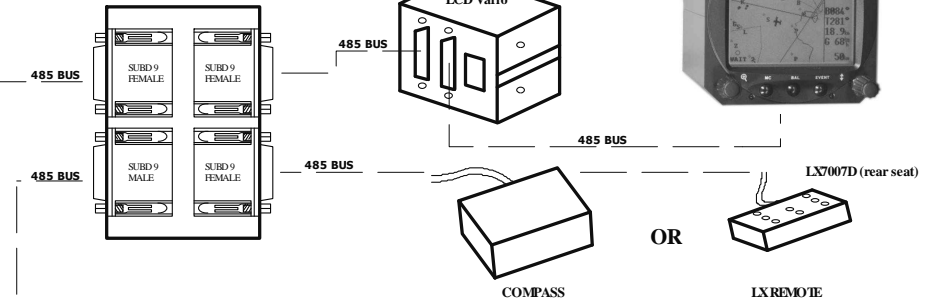

**LX 7007 DIGITAL UNIT Wiring**

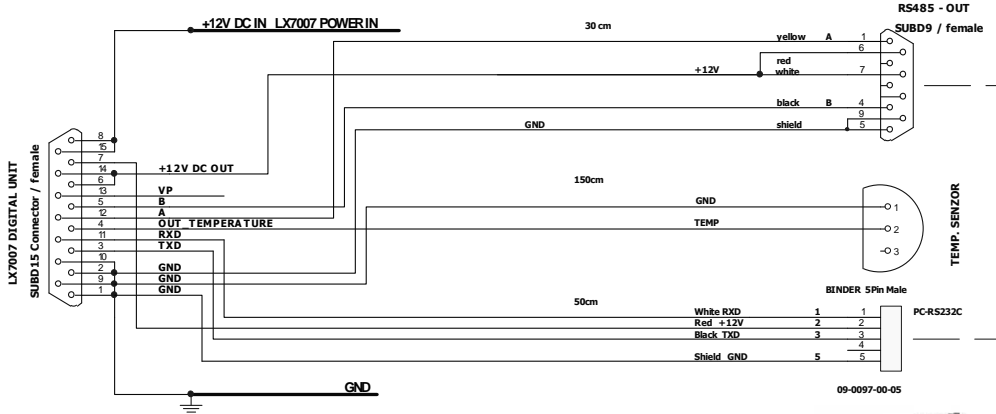

**LX5PC CABLE**

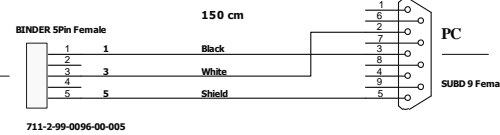

PC

**LX7COL CABLE**

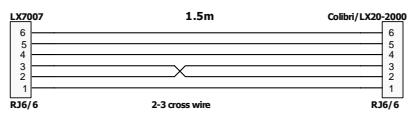

COLIBRI OR LX20-2000

**CABLE LX1636 / LX1638**

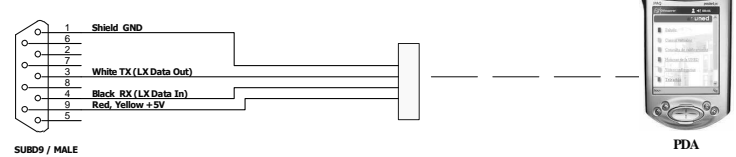

PDA

**LX7000 / LX20 Communication Cable (delivery not included)**

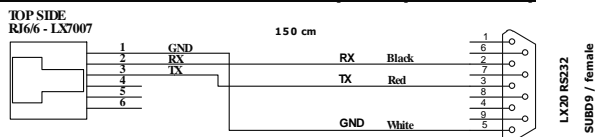

# 5.6 Tree structure Diagram

←MODE→

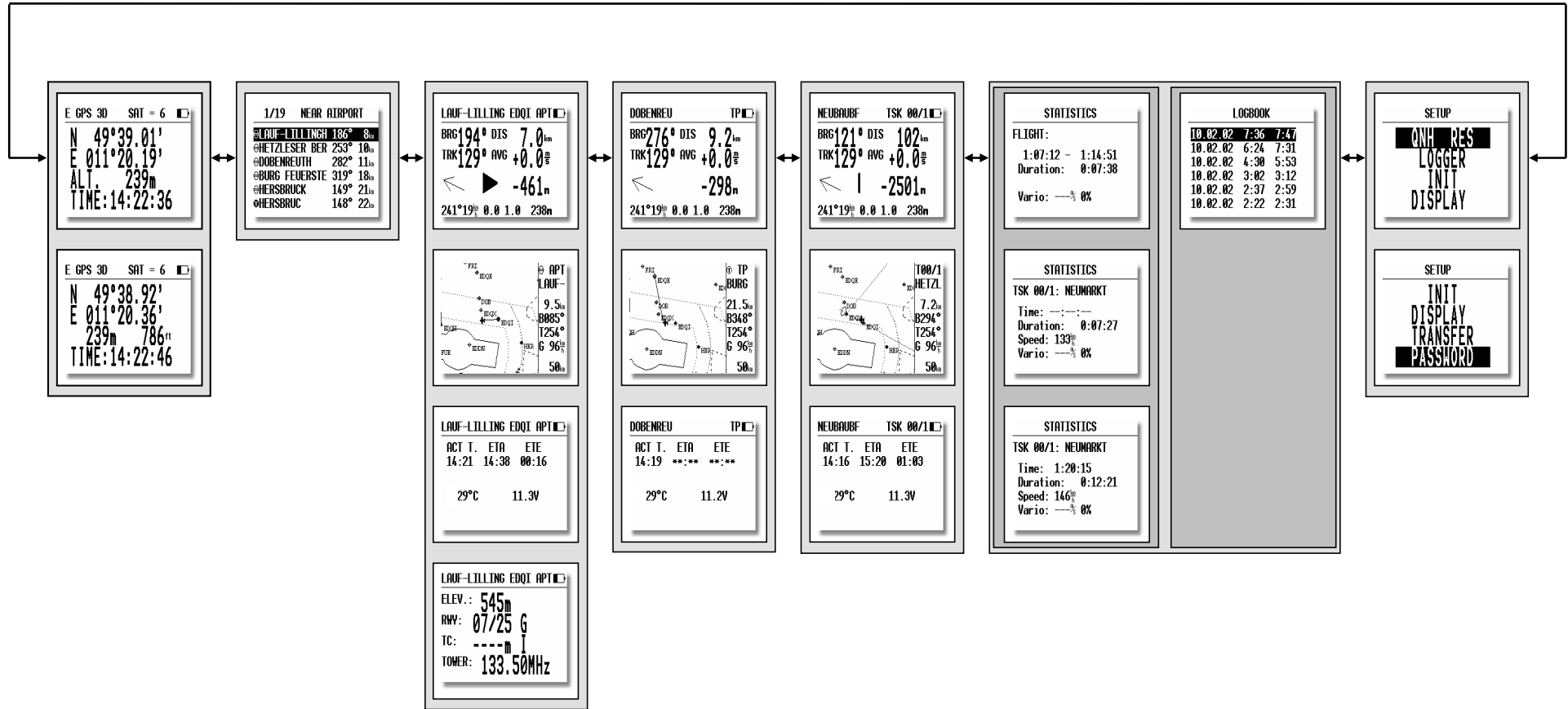



simulator. The unit will change over to flying mode automatically after ground speed will be detected. This imitates a very real situation, ensures statistics data and also final glide training. In general, every simulator which sends GGA and RMC sentences at 4800 bps is acceptable (LXsim). In that case the altitude information will miss.

## 6.1 HW configuration

It is recommended to use Colibri power and data set (Ord. Nr.COL-AC-PC), which will power and also connect your LX 7007 to PC.

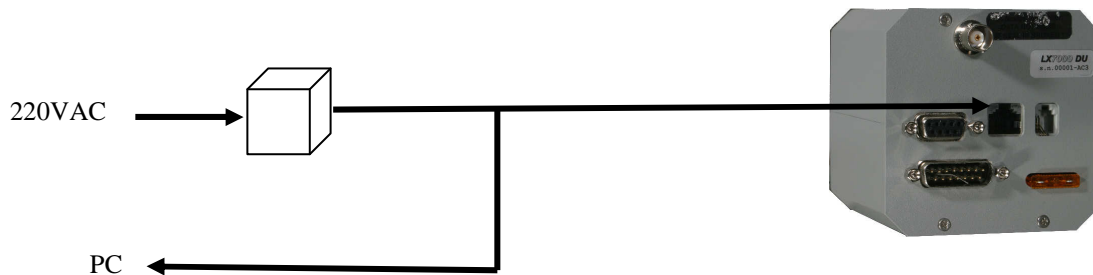

Use exclusively **IGC marked** connector on LX 7007. Using of Colibri adapter makes also possible to arrange communication PC - LX 7007 after IGC item is selected in TRANSFER. Original wiring may be also used, in that case use 5P round connector and the PC cable.

### 6.1.1 Input of passwords

To enable simulator mode it is necessary to input special password on LX 7007.

PW	Port on LX7007	Wiring
55556	IGC	Colibri adapter
55557	PC	Original LX wiring and PC cable

**Note!**  
It is not possible to produce valid flights that way.

## 6.2 Condor and LXsim

Condor is a flight simulation PC program available under [www.condorsoaring.com](http://www.condorsoaring.com). The program is not delivery included. LXsim is a free LX Navigation program available at any time by LX Navigation.

# 7 Options

## 7.1 Flarm option

Flarm is a collision avoidance system developed by Flarm Technologies from Switzerland. LX Navigation and Flarm Technologies signed a contract under which LX Navigation got rights to integrate Flarm technology into LX Navigation products.

A Flarm module consists of following main parts.

- GPS receiver
- Microcontroller unit
- Radio Transceiver
- Pressure altimeter
- Flarm external indicator

**Note!**

It is also possible to replace Flarm external indicator (LED) with Flarm graphic display. Even using both in parallel is possible.

The GPS receiver defines position of the glider, the microcontroller is responsible for collision prediction calculations and the transceiver is sending and receiving data.

### 7.1.1 Configuration

All electrical parts are integrated into LX 7007 cabinet an exception is radio communication antenna and Flarm External Display. See capture 7.1.2. There is no manipulation or inputs on LX 7007 side at all. Some inputs are possible on external display.

#### 7.1.1.1 Flarm external display

**Flarm External Display** is mainly used like collision warning interface and status indicator. To connect both units use original cable (6P-6P telephone type) delivered with the unit. Use connector on the back side of the LX 7007 marked FLARM. The unit is **powered** from LX7007. Delivered is an external display developed by LX Navigation, which is slightly adapted to work with LX 7007.

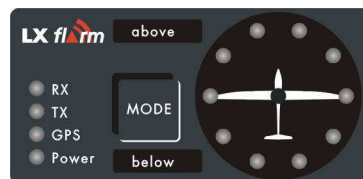

- 10 radial positioned red LEDs, defines **direction to** the near glider (top LED active means frontal collision risk)
- 2 additionally red light emitting diodes marked like **above** and **below** informs about vertical position of the glider, which is close.
- **Mode** button is used to control the unit, see table below
- 5 green status LEDs. **Power** indicates presence of power and data (blinking, if no data received from Flarm unit), **GPS** status (bad blinking), **Tx** transmit detection, **Rx** receive detection.

The external display has two modes of operation:

- **WARNING Mode** will activate a red blinking diode and an audio alarm will be executed, if there is a **collision** prediction.
- **NEAREST Mode** will show the position of nearest glider, red LED will light **permanently** and there will be **no audio**. The unit will change over to Warning Mode **automatically**, if **warning** criteria will be fulfilled and will continue in NEAREST after warning will disappear.

- Pressing of MODE selector for approximately **4 seconds will deactivate** Flarm external display for 5 minutes, no **warnings** and no **near** information will be displayed during this period. A very typical situation only Power LED on will characterize this status.

**Note!**

To change mode of operation press **MODE** button for approximately 2 seconds. If the radial LEDs will run from top toward bottom means change over to NEAREST and vice versa. After new power on, the mode active before switching off will remain.

- **Obstacles**

Flarm electronic is capable to store coordinates of obstacles which could cause collisions during flight. This data is available on [www.flarm.com](http://www.flarm.com), use Flarm tools to transfer, and respect capture 7.1.7.

An obstacle warning will be activated, if an obstacle is to be found in the front of the glider.

After a low level warning has been activated two upper and two lower LEDs will be active (such a situation will never appear by glider collision risk). Medium and high risk will be indicated with more LEDs active and audio signal.

#### 7.1.1.1 LX Flarm graphic display

This type of display is 100% compatible to LX 7007 Flarm output and may be used instead of LED version . See manual for details.



#### 7.1.1.2 LX Flarm display 57 mm

This unit is an air norm unit and replaces LED version also.





### 7.1.1.2 Settings

Using of mode selector key is possible to adjust some parameters of external display. Disconnect the unit, press mode selector and hold, power on, hold mode selector for about 4 seconds. The display parameters can be defined pressing mode selector for approximately **2 seconds** and observing green LEDs. To move in-between parameter press short mode and observe **red LEDs**.

Parameter	LED	Red LED 018	Red LED 054	Red LED 090	Red LED126	Red LED162	Red LED 198
<b>Twin config.</b>	Tx	PIC	PAX				
<b>Baudrate</b>	Tx+Rx	4800 bps	9600 bps	19200 bps	-----	38400 bps	57600 bps

**Note!**  
In conjunction with LX 7007 use exclusively 19200 bps.

If two units will work in parallel (double seater), one unit must be PIC and another PAX.

### 7.1.2 Installation

The position of radio communication antenna is extremely important, bad installation will reduce the system range dramatically. It is hardly recommended to install the antenna on the top of the instrument panel, a suitable aluminium round plate having a diameter about 12cm is used as a back plane and approximately 10 cm long rubber antenna is used like radiator. The metal plate may be mounted outside or inside of the instrument panel. If carbon is used, use only top mounting variant.

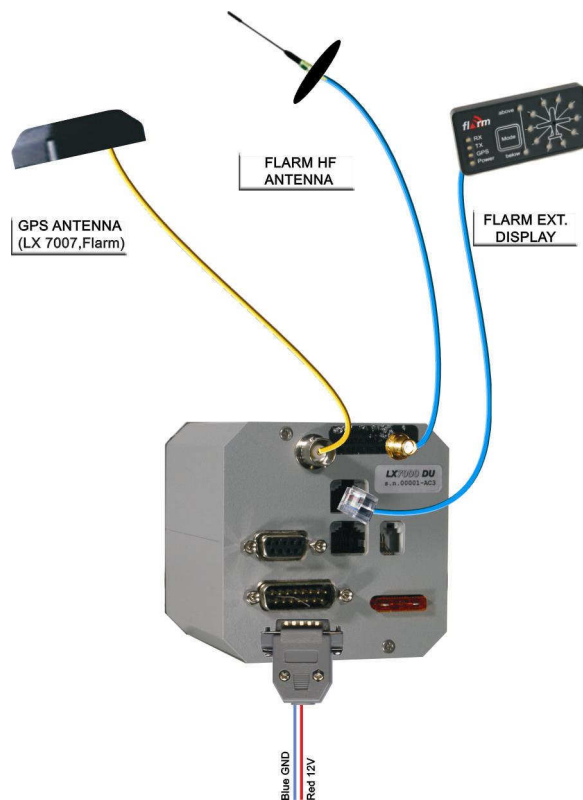

**Note!**

The antenna position must be as much as possible vertical. Use only original antenna which is always delivered with the unit. Use original cable to Connect LX 7007 and antenna. Never use antenna without original aluminium ground plane. Having no space to install metal back plane, dipole variant of antenna is available.

The Flarm external display is a small unit and can be placed somewhere on the instrument panel. To fix the device use self adhesive back side of the device. If a position on the top of the instrument panel will be chosen, LX Navigation offers a suitable box.

**7.1.3 Functional check after installation**

After LX 7007 has been switched on the Flarm External Indicator will receive power and will pass initial routine which will take several seconds.

1. Power LED indicates presence of power, blinking means no data received from 7007
2. GPS LED informs about GPS status, blinking GPS bad, light GPS OK
3. Tx indicates transmission, only active by GPS OK (blinking)
4. Rx indicates presence of another Flarm
5. Check functionality of mode key, each short press will activate audio for a short time

**Note!**

After installation obligatory check functionality from 1 to 3 and 5.

Error messages:

After Flarm failure will be detected the LX 7007 will show this situation during booting routine like **Flarm self test not OK**.

**7.1.4 LX 7007 traffic information display**

If the unit receives Flarm collision relevant data is capable to offer a wide range of very useable functions which will make Flarm in conjunction with LX 7007 much more sophisticated.

After a short press on **EVENT** button will open Flarm graphic display and actual traffic situation will be visualized. The display orientation can be selected in setup Flarm. All near gliders are present on the display and detailed data of **one glider** is displayed in the left upper corner of the display. **The glider selection** is possible after using of **up/down** (⇅) switch. A **line going** from the centre of the display to the glider defines selected glider.

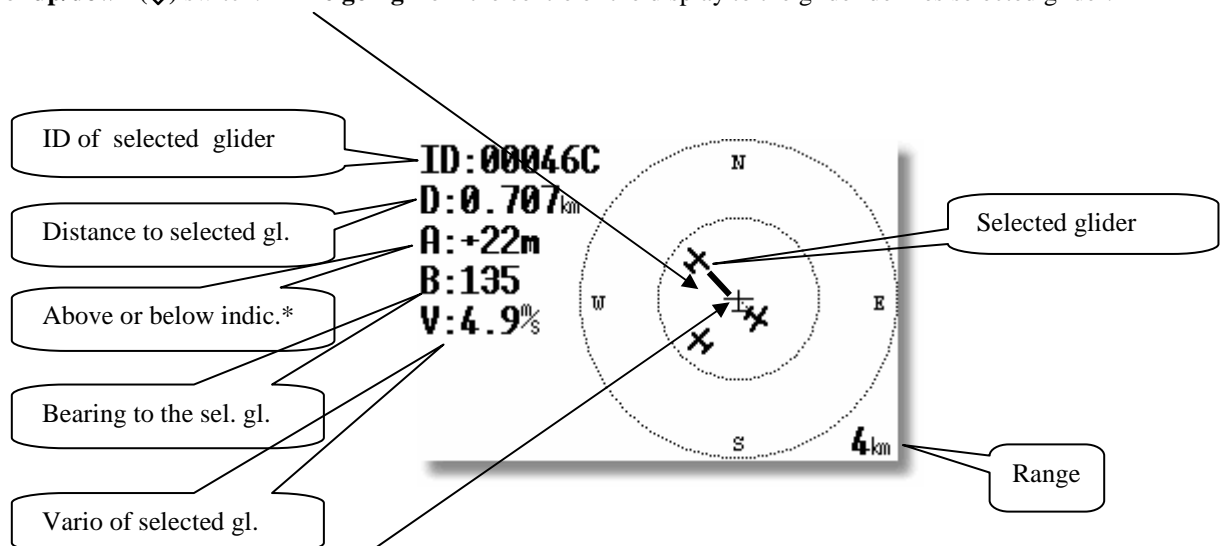

The **central positioned glider** which silhouette is not bold, illustrates reference point of the system in fact this is the glider where the pilot is sitting.

Character A can have + or - sign; + means above and - means below in meters or ft.

**Range** adjustment is possible after using of ZOOM.

### 7.1.4.1 Glider ID customization

As the Flarm ID number of the near glider doesn't say a lot of, a customisation of mentioned ID is possible for known gliders. If one known glider is in radio range the pilot is able to customize its ID into more covenant form, let say competition number or something similar. After customisation this particular glider will always be represented with its customized ID. The procedure:

-select the glider of interest after using of ↕

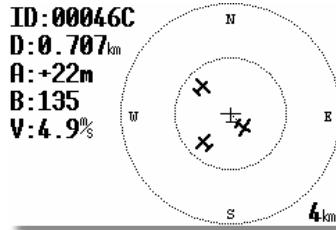

-press **enter** and a menu will open, select **successive** number and input **custom ID**

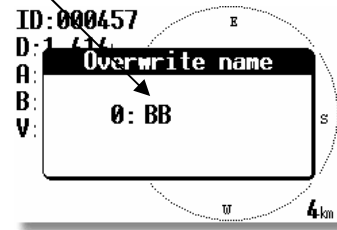
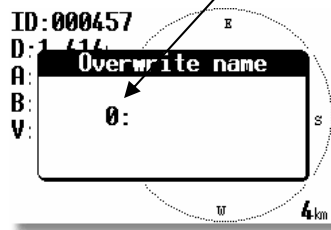

LX 7007 has space to store up to 10 customized Flarm IDs. An already customized ID can be edit at any time.

Some pilots are using so called **Privacy function**, also called as Stealt. Doing this they transmit only minimum collision relevant data and such a gliders are not described with glider symbol, they are present like dots on the LX 7007 display. The command to activate Privacy function and vice versa can be also sent from LX 7007, after using of Seup/Flarm.

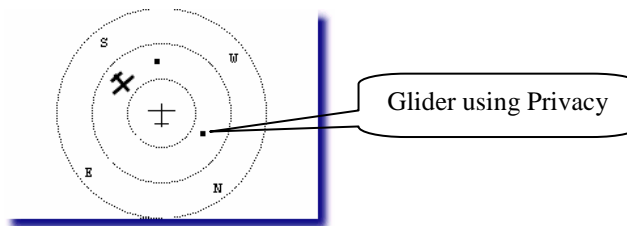

### 7.1.5 Manuals and limitations

Before using obligatory read following manuals:

- Flarm user manual [www.flarm.com](http://www.flarm.com)

**Note!**  
Respect all limitations listed in mentioned documents.

The manuals are published on LXe CD.

### 7.1.6 Flarm firmware updates

Flarm is a separate board integrated into LX 7007 housing. The only way to provide firmware update is to connect Flarm board with PC. A suitable **cable** designated as Flarm Update cable (Ord. nr. LX7-F-UD-cable) is delivered with **every** unit.

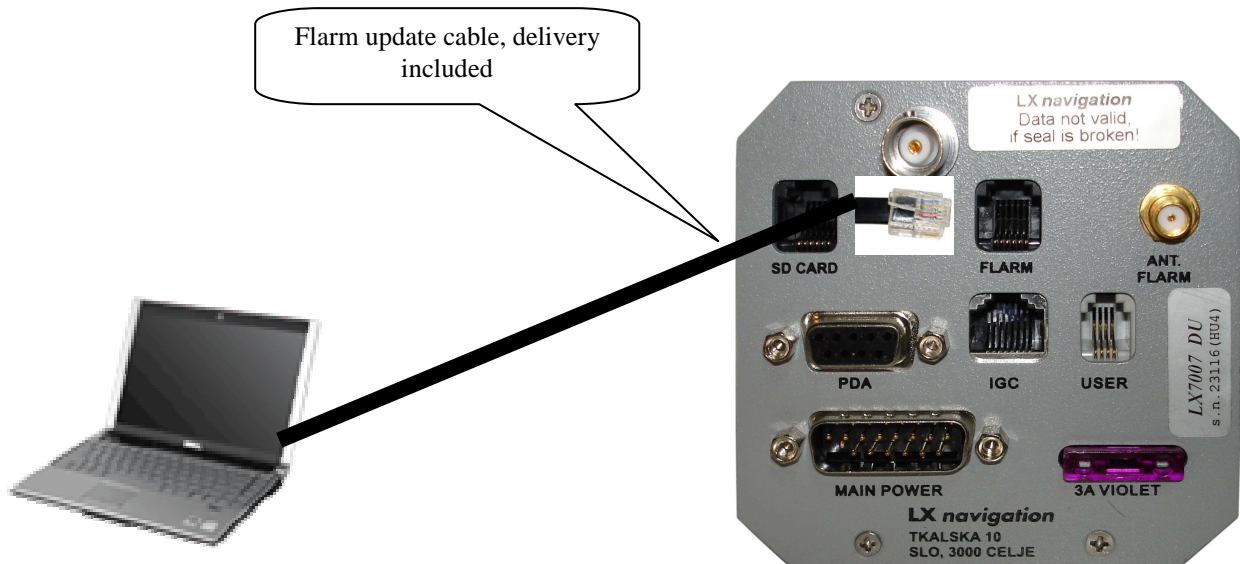

It is necessary to **disconnect** Flarm external display and to plug 6P telephone type connector of the Flarm update cable into FLARM marked socket of LX 7007.

If FLARM marked connector isn't easy to reach, use a RJ11 female to female interface which is available in nearly every telephone shop. This will make possible to connect the update cable close to the Flarm External display and this position is normally easy to reach.

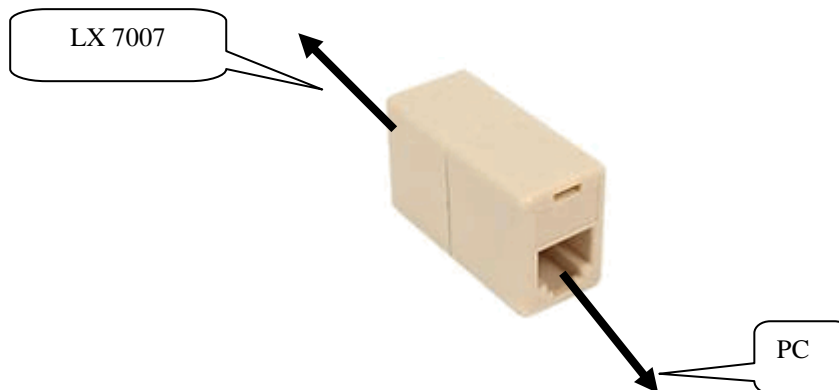

### Procedure Nr.1

- Switch **LX 7007 ON** and wait until booting will finish
- **Run** Flarm tool (a free com port will be selected automatically)



Flarm tool ready on com 2

- **Remove** Flarm external display
- **Connect** Flarm update cable to **PC (9P)** and **LX 7007 (6P)**
- **Wait** until connection will be **established** (it will take up to 30 seconds)

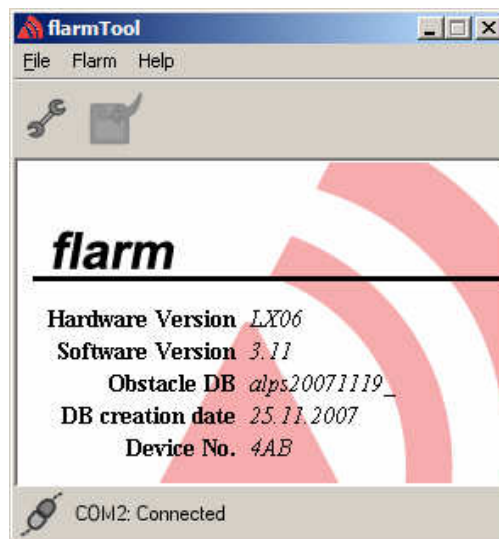

Connect status established  
(HW,FW, data base and device number visible)

**Note!**

If Flarm will **not connect**, close Flarm Tool and try again.

- The update procedure will start **automatically** immediately after connection
- Follow wizard on PC and wait until **Finish**

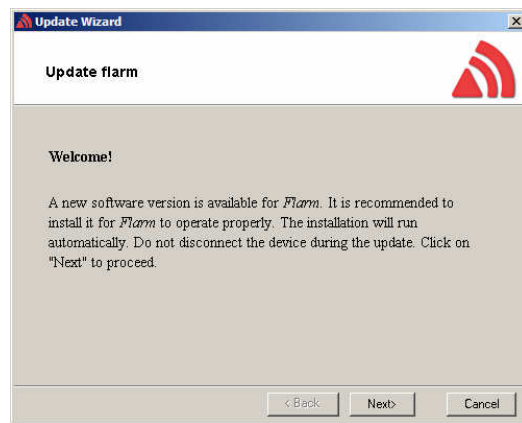

- **Close** Flarm Tool
- Switch LX 7007 **OFF and after ON**
- **Reconnect** Flarm external display and provide **functional test**

By no success use procedure Nr. 2

### Procedure Nr.2

- Input **password 41000** on LX 7007 System Setup\Password
- A message window will open



- **Run** Flarm tool
- Click on **Flarm** and after on **Recover**

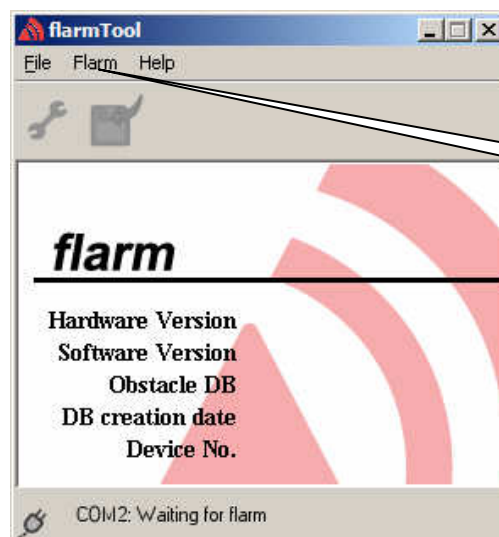

- Follow **Wizard**
- The update will **run automatically**
- After a PC **message** “ The device has successfully been updated” , click on **Finish**
- Press **Enter** on LX 7007
- Switch LX 7007 **off and after ON**
- **Reconnect** Flarm external display and provide **functional test**

## 7.2 LX 7007 PRO IGC - Compass Module

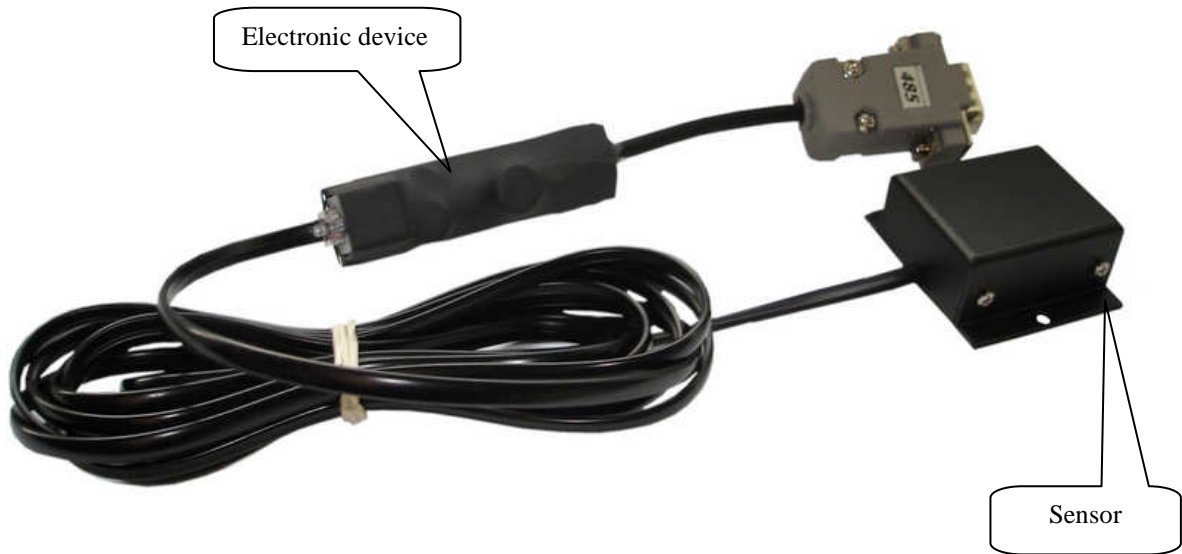

### 7.2.1 General

The compass module is an electronic compass device (magnetic field sensor), which was developed for the LX 7007 PRO IGC. The LX 7007 PRO IGC recognizes the compass module automatically when it is coupled onto the 485 bus. This manual is valid for LX 7000 also. The only configuration settings needed relate to the compensation procedure. An indication that the compass module is connected is the appearance of magnetic HDG reading on navigation page 3 of the LX 7007 PRO IGC.

AIGEN	AIGEN	LOXA	APT
BRG	346°	DIS	292 <sup>km</sup>
TRK	090°	GS	172 <sup>km/h</sup>
DTK	346°	HDG	212°
0.2 <sup>km</sup> [.....†.....]			

Mg. heading indicator

**Note!**  
Heading indication is default **Magnetic**, after a change of setting in UNITS the indicated heading may be **True**.

The compass module not only permits the display of magnetic heading but also permits the calculation of the **wind vector in straight flight**. The wind vector is calculated using the triangle of velocities method, where the vectors of ground speed with track, TAS with compass heading, and the wind vector form a triangle of velocities.

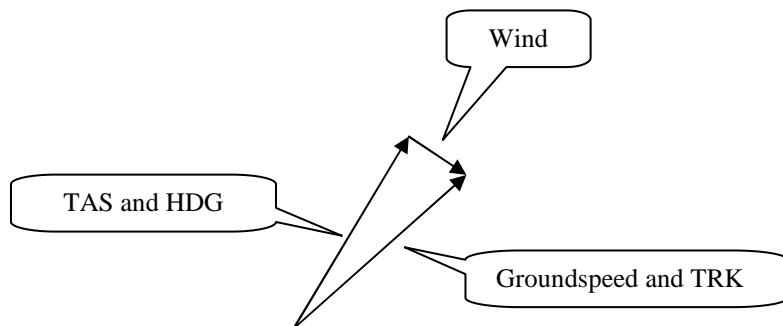

The angular difference between HDG and TRK depends on the magnitude of the wind vector and is normally quite small, which means that the measurement has to be quite precise if accuracy is to be achieved. While the GPS data (TRK and GS) is precise, small inaccuracies in the heading of about  $5^\circ$  can cause errors of up to 25km/h in the wind strength. This method only works during straight flight and the calculation is stopped as soon as HDG and TAS change rapidly as occurs when the glider is turning.

## 7.2.2 Installation of the compass module

The device consists of two parts, a compass sensor and electronic device. The compass sensor should be built somewhere far from iron parts, which can cause errors in reading. Respect flight direction arrow and install the unit horizontal. All Connections are plug\_and\_play, so there is no mistake possible. A **485 splitting** unit to extend LX 485 bus is included. The box with electronic could be installed on the convenient place in the glider, orientation doesn't matter.

The **orientation** is clearly marked on the label which is on the bottom of the unit.

### 7.2.2.1 Where to install:

The compass module should be installed as far as possible away from magnetic, electrical and steel parts (loud speakers and analogue vario indicators contain strong magnets). Even the mechanical compass should be as far away from the sensor as possible. Minimum distance is 20cm. As mentioned above, the arrows should be aligned accurately in the flight direction and parallel to the fore and aft axis of the glider. For a proper installation a plane area parallel to the horizontal plane is needed.

### 7.2.3 First test after installation:

An external reference compass is required which can either be a prismatic landing compass or a calibrated compass base on the airfield surface. Using the reference compass, the glider should be aligned in each of the eight main directions ( $360^\circ$ ,  $45^\circ$ ,  $90^\circ$ ,  $135^\circ$ ,  $180^\circ$ ,  $225^\circ$ ,  $270^\circ$  and  $335^\circ$ ). Now the glider should be oriented into north direction, while doing that watch the HDG displayed on Nav.-page 3 of the LX 7007 PRO IGC (do not try to compensate the compass yet!). If the HDG varies more than  $\pm 5^\circ$ , rotate the compass so, that the deviation decreases below  $\pm 5^\circ$ . Now turn the aircraft into the other directions and read the displayed values (don't change the compass position anymore). If they vary more than  $\pm 15^\circ$  look for another place for the compass module.

### 7.2.4 Adjusting the compass module:

The compensation of the compass is made in the SYSTEM SETUP/COMPASS.

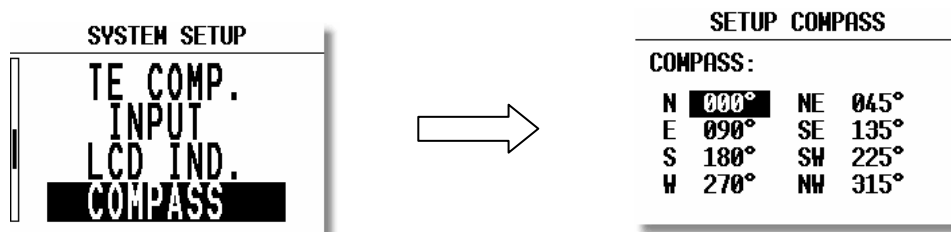

1. Orientate the glider again to  $360^\circ$

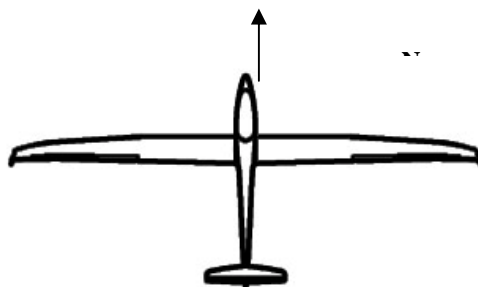



2. Set the cursor on **N** and press ENTER (actual measured **HDG** is displayed).
3. Press **ENTER** again (storing of measured value)
4. Set the cursor on 45°, rotate **the aircraft to 45°** press **enter**, stabilize reading and press **enter** again to **store** the measured value
5. Repeat the procedure for the remaining directions

SETUP COMPASS			
COMPASS:			
N	000°	NE	045°
E	090°	SE	135°
S	180°	SW	225°
W	270°	NW	315°

SETUP COMPASS			
COMPASS:			
N	004°	NE	045°
E	090°	SE	135°
S	180°	SW	225°
W	270°	NW	315°

Example:

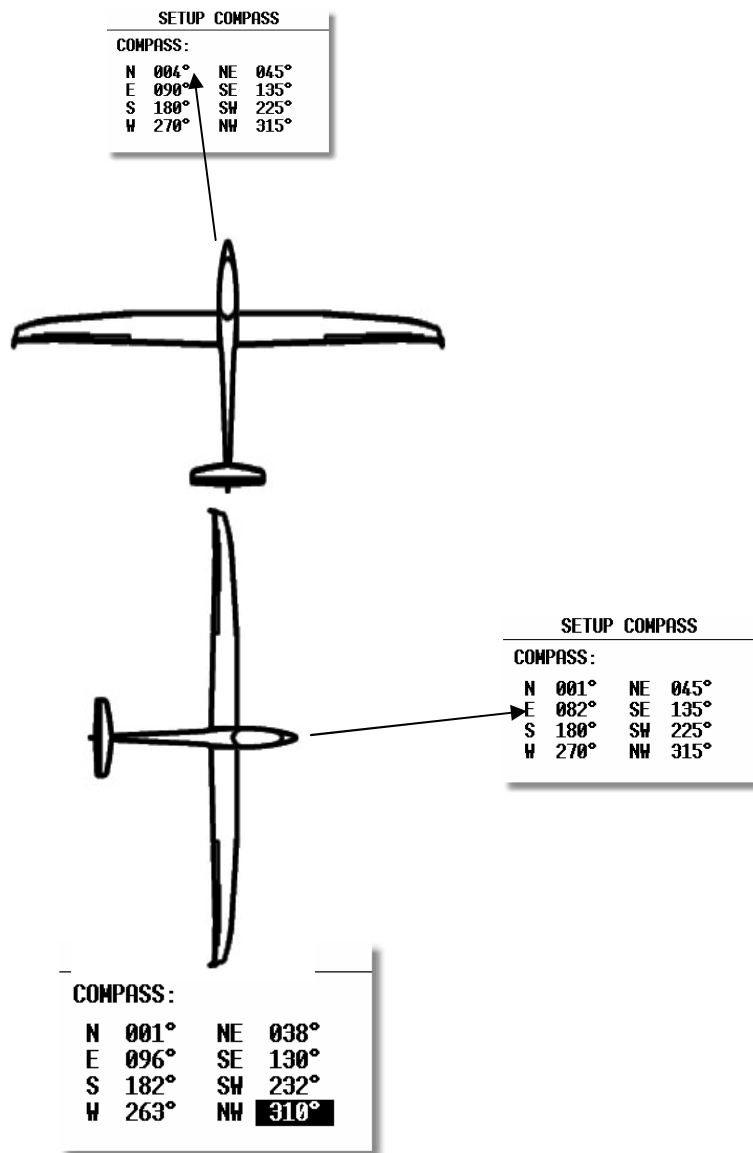

Typical situation after successful calibration procedure

Leave menu with **ESC**.

**Important!**

Switch the unit **OFF**, by using esc/off button to store calibration data properly. The calibration data will remain until next calibration procedure.

### 7.2.5 Final check

Switch the LX 7007 PRO IGC back to Nav.-Page 3 and check again all 8 directions. The error should now be less than  $1^0 - 2^0$  (better to have  $1^0$  !). If the errors are larger, then one should search for faults in installation or in the adjustment procedure. When the final test is satisfactory, your LX 7007 PRO IGC is ready to calculate the wind with the compass method.

**Note!**

The calibration is specific for your combination of aircraft and compass, which means you, can not transfer the compass to another aircraft while using the same calibration values. The parameters are stored in an EEPROM, so they will not get deleted when a memory initialization is performed or the internal Li-battery is exchanged.

It is recommended to repeat the calibration procedure every year.

### 7.2.6 Input of local mg. variation

The correct input of local mg. variation is **absolutely necessary**, use **INIT/QNH RES** menu. Wrong mg. variation may **degrade** wind calculation significant.

## 7.3 LX 7007 Remote control

### 7.3.1 LX 7007 PRO IGC – Remote K- Stick mounted unit

#### 7.3.1.1 General

All necessary electronic is built into the top of the stick and only for wires should be provided from the handle tube to the interface unit, this solution makes the installation very easy. Additionally two shielded cables are used for speed command key and PTT.

**Note!**

Don't forget to initialize speed command input setting to TASTER (SETUP/INPUT)

#### 7.3.1.2 LX 7007 PRO IGC Remote K configuration

There are two units:

- Leather coated stick with built in electronic

**Note!**

The stick is delivered in three diameters, 19.3, 20 and 24 mm. LS gliders requests 24mm, all other glider types will accept 20mm.

- Interface printed circuit board which connects wires coming out from the stick to the LX 7007 485 system bus.

#### 7.3.1.3 Stick handle with keys

The original stick grip should be removed and replaced with the new one. On the top of the new grip there are 9 push buttons. An additional button positioned on the front side is for climb/cruise change over. Both PTT and climb/cruise buttons are wired separate. All remaining buttons are Connected to the built in microcontroller and only four wires should be Connected to the 485 system bus. A very small interface printed circuit board Connects four wires coming out of the stick to the 485 System bus.

**Note!**

After successfully installation, there is no special setting required on LX 7007 side, a very clear message "REMOTE DETECTED" during booting routine will inform about presence of this interface.



#### 7.3.1.4 Double seater configuration

The stick may be installed into both seats. The front seat mounted will control main unit and the rear seat mounted will control the repeater.

**Important!**

The front and rear stick are not identical and must be installed correctly. Sticks for second seat are clearly marked.

## 7.4 Secondary vario indicators

An unlimited number of secondary vario indicators can be connected to the system bus. 485 splitting units should be used to extend the bus capacity. The functionality of secondary units depends on settings done in setup (2.1.2.16). Each unit has two female 9P Connectors on the back side. Both Connectors are 100% pin to pin compatible and doesn't matter which will be used. Any other 485 bus operated unit can be any time Connected to a free Connector port of the vario indicator.

## 7.5 LX 7007 D for second seat

This is a similar device as LX 7007 DU, but has been developed to serve as a unit installed in the second seat of the glider. The unit is also 485 bus participant and therefore doesn't need separate power supply, it is supplied via bus. Details are described in a separate LX 7007 D manual

## 8 Revision history

<i>Apr 2005</i>	<b>1.0 new done</b>
<i>Jan.2006</i>	<b>1.04, Flarm option,</b>
<i>Jan 2007</i>	1.048
<i>March 2008</i>	1.11
<i>June 2008</i>	1.2,alt.gain, total average,comp. mode, start monitor
<i>Feb.2009</i>	2.0, DME, auto move
<i>May 2009</i>	2.01 IGC file on SD